

# Installation Guide

Installation Kit: 911-8104-10



For all John Deere 8030 series tractors with factory flowmeter and standard front axle

Flowmeter circled in red below. Flowmeter can also be located near the batteries

## John Deere

8130

8230

8330

8430

8530

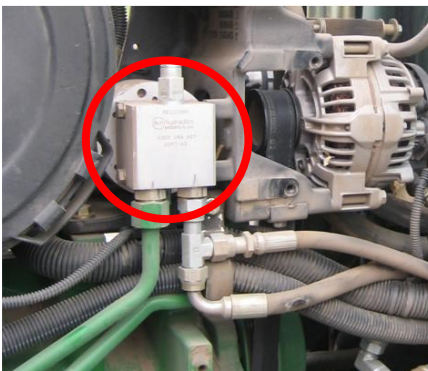

# Introduction

---

## **WARNING!!!**

**Unexpected machine movement may occur when creating a new machine profile, switching machine profiles, changing valve type setting, or connecting a terminal with a different machine profile active.**

**Ensure the 3 position power switch is in the center (roading) position before performing any of the above operations until the proper machine profile and valve type is selected.**

The procedures outlined in this guide provide the basic installation procedure for the eDriveM1 on the machines specified on the front cover of this guide. If you do not see your machine listed, contact customer support for further instruction. The kit components and corresponding install instructions are designated for each applicable machine make and model and may not be used on undesignated machine models.

### **Review Installation Kit Contents**

Kit contents are outlined in the following pages of this installation guide. Read all applicable installation instructions for your machine's model and ensure that all required kit components are present before beginning the installation.

### **Read and Follow All Safety Messages**

- Refer to the safety manual for the machine that the eDriveM1 is being installed on for operating age and precautions.
- Prior to installing and operating the eDriveM1, read and understand all safety precautions as outlined in this guide.
- Store this guide and all related safety information with related machine manuals for future reference.

# Introduction

---

## **Safety Information and Warnings\***

- eDriveM1 is NOT designed to replace the machine's operator and is designed as a driving aid for use in precision agriculture applications.
- eDriveM1 is NOT intended for use on roadways and should remain disengaged at all times when traveling on roadways.
- eDriveM1 does NOT control the speed of the machine and a human operator is required to manually maintain a safe operating speed.
- eDriveM1 does NOT avoid obstacles. To prevent human, machine and property injury a human operator is required to operate the machine at all times.
- Do NOT allow anyone to operate without instructions.
- At all times the driver is fully responsible for the safe operation of the vehicle.

\* The safety warnings contained in this installation guide are not meant to be an exhaustive list of potential hazards.

- To ensure peak performance, eDriveM1 should only be installed after a thorough machine inspection has been conducted. The contents of this kit and eDriveM1 are not intended to replace preventative and or needed maintenance. To avoid bodily and machine injury, follow the machine preparation checklist below:
  - ⇒ Inspect steering linkage: Machine should drive in a straight line without manual correction
  - ⇒ Turn off machine and power-off all electronic gauges, monitors and external devices when installing or performing maintenance on the eDriveM1
  - ⇒ Park machine on a clean and level surface
  - ⇒ Lower all implements and headers to the ground
  - ⇒ Apply the parking break and chock wheels
  - ⇒ Inspect any drilling and/or cutting sites to ensure no electrical wiring damage will be incurred

# Cabling Diagram

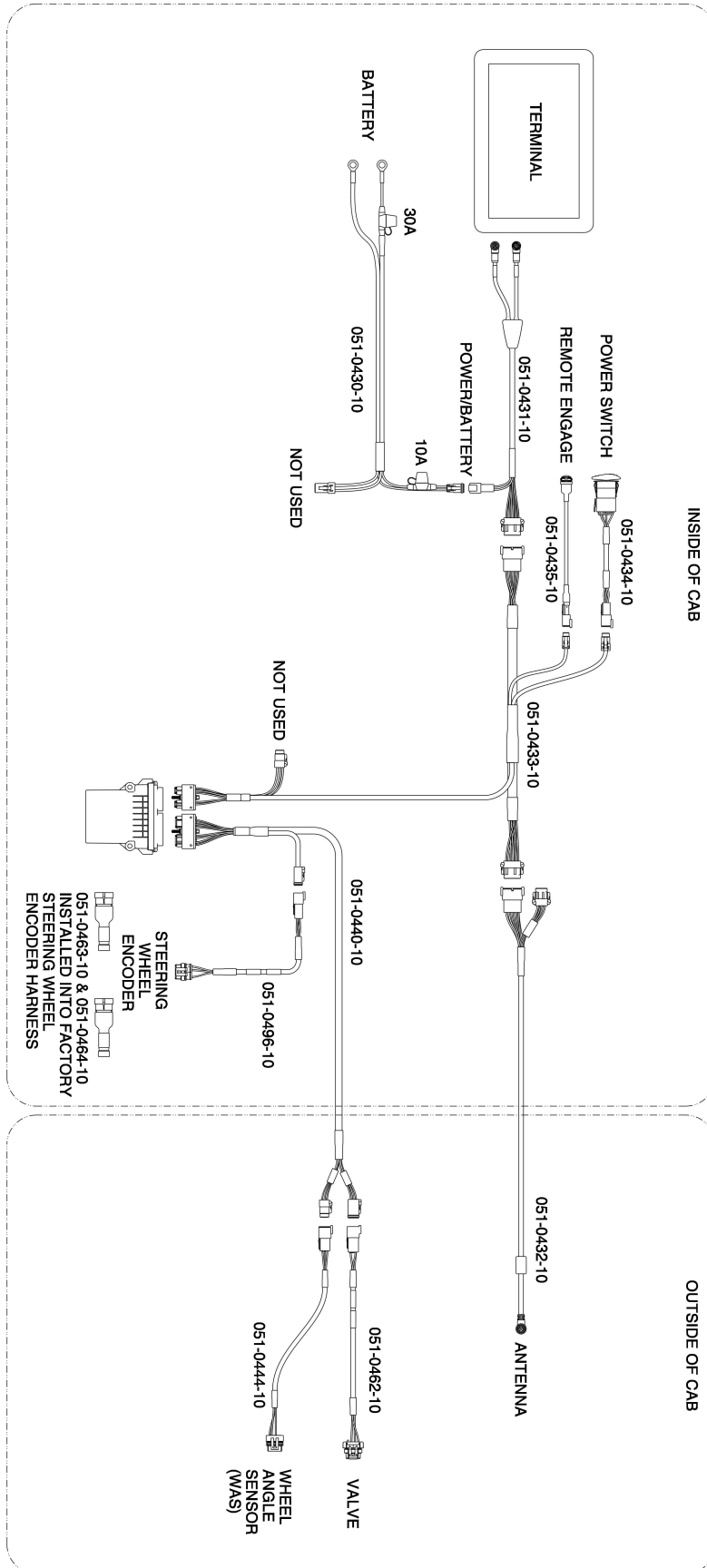
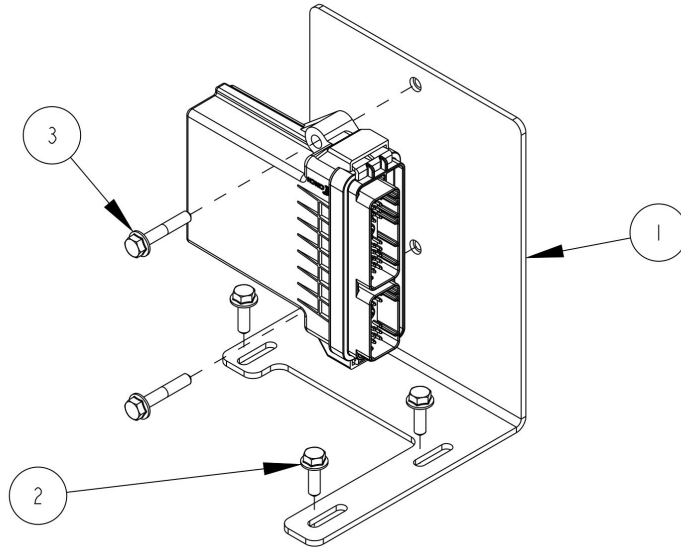

Figure 1



# ECU installation

Required items for ECU install listed below



ITEM	QTY	PART NUMBER	DESCRIPTION
1	1	640-0208-10	BRACKET, ECU, EDM1, DEERE
2	3	675-1352-10	SCREW, FLANGE, HEX, M6-1.0x20
3	2	675-1362-10	SCREW, FLANGE, HEX, M6-1.0x35

Figure 2

Pull up the floor mat to the left of the operators seat to gain access to the ecu bracket mounting location. Remove the 3 bolts circled in red.



Figure 3

# ECU installation

Use the 3 shorter M6x20 bolts (item 2) to secure the ecu bracket (item 1) to the floor of the cab.



Figure 4

Lay the floormat back down over the bracket.

Attach the eDriveM1 steering ECU to the bracket using included hardware (item 3)

ECU shown in Figure 5 is installed with logo facing right and connector pointing rear. This orientation will need entered into the display for the first calibration step.



Figure 5

# Wheel Angle Sensor Installation

Required items for WAS install listed below

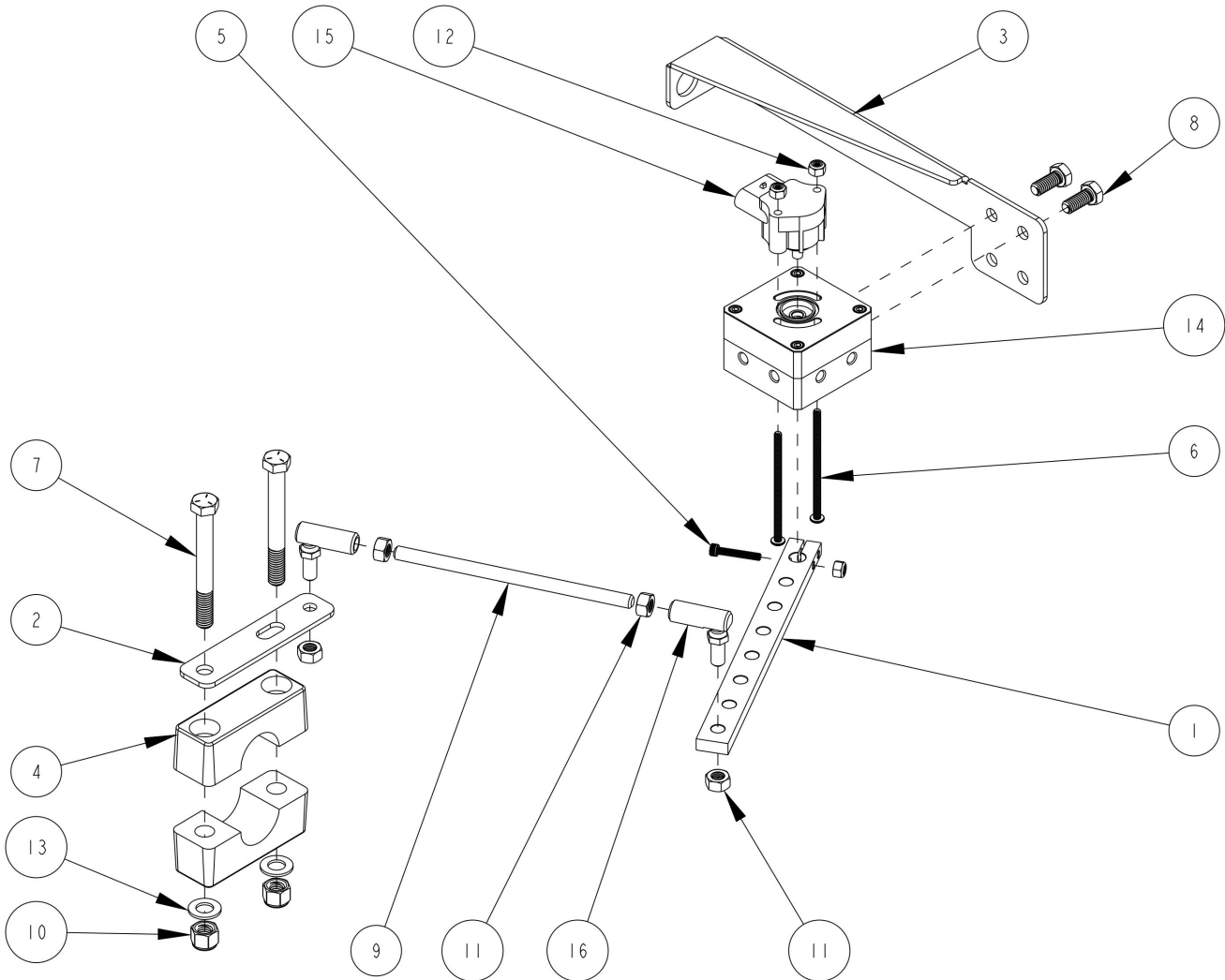

ITEM	QTY	PART NUMBER	DESCRIPTION
1	1	602-1087-000	CONNECTOR ARM
2	1	640-0070-000	WAS ROD MOUNT
3	1	640-0104-000	WAS HOUSING MOUNT
4	2	675-0106-000	CLAMP- 1-1/4"
5	1	675-1150-000	SCREW- SOCKET HEAD, 8-32x1"
6	2	675-1191-000	SCREW- PHILLIPS HEAD, 8-32x3"
7	2	675-2005	BOLT- HEX, 3/8-16 x 3.25", GR5
8	2	675-2010	BOLT- HEX, 5/16-18 x 3/4", GR5
9	1	675-2031-000	THREADED ROD- 5/16-24 x 12"
10	2	676-1035	NUT- NYLOK, 3/16-16
11	4	676-1053-000	NUT- 5/16-24
12	3	676-1054-000	NUT- NYLOK, 8-32
13	2	678-1054	FLAT WASHER- 3/4" x 13/32"
14	1	720-0045-000	WAS HOUSING ASM
15	1	750-5002-000	SENSOR, WHEEL ANGLE
16	2	760-0018-000	ROD END, SWIVEL, 5/16-24

Figure 6



# Wheel Angle Sensor Installation

Position the sensor on the housing as shown in the picture to the right. Use (item 6) and (item 12) to secure the sensor to the housing

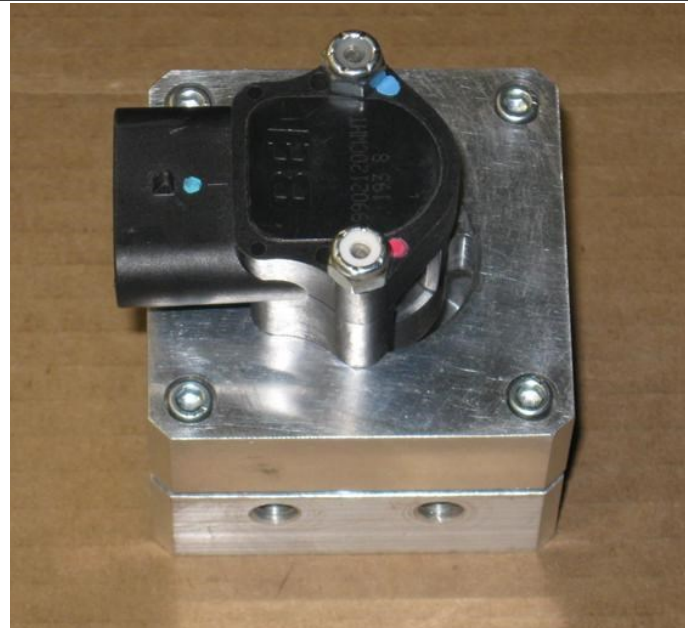

Figure 7

Cut 4 holes off of the WAS arm (item 1) opposite of the WAS shaft mounting hole (circled in red). See picture right for reference.

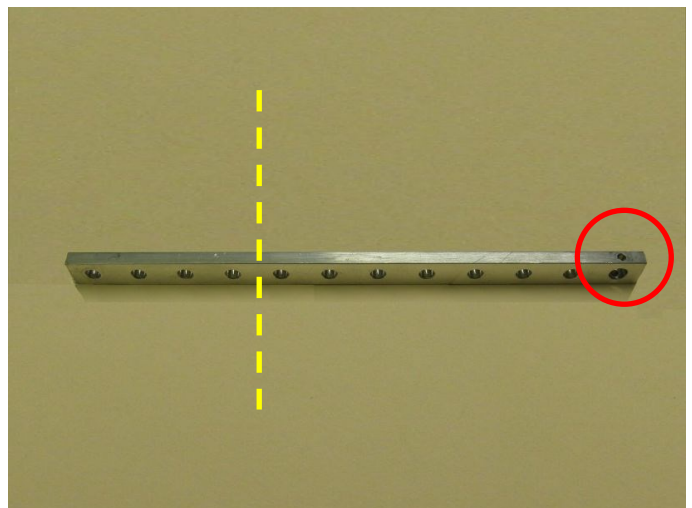

Figure 8

Attach the WAS arm to the WAS sensor housing assembly. Make sure the WAS arm is facing the same direction as the sensor connector.

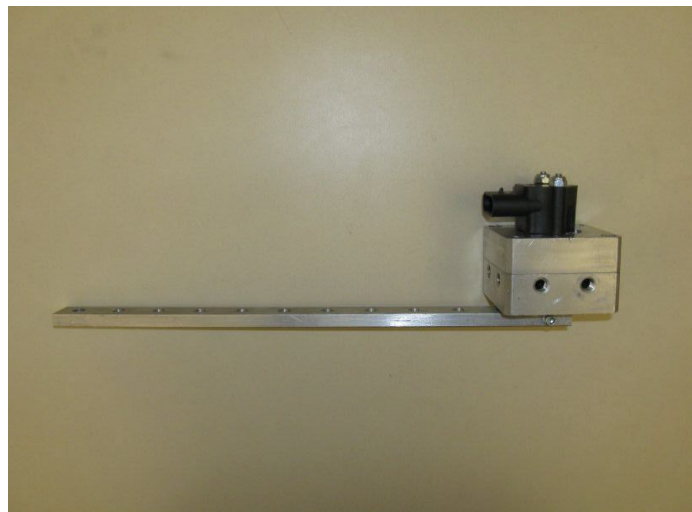

Figure 9

# Wheel Angle Sensor Installation

Check which axle type your tractor has. The axle type determines the length of the cut threaded rod and the assembled threaded rod .

Notice axle type 2 has a gap between where the bracket mounts and the square block on the axle housing

Axle Type 1



Figure 10

Axle Type 2

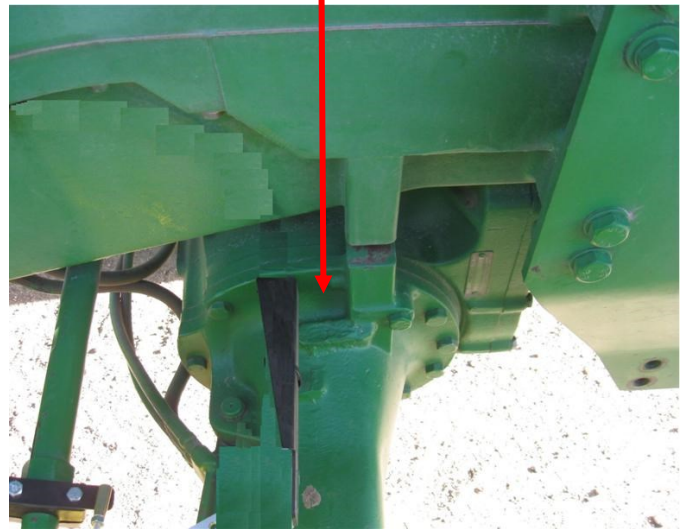

Figure 11

Screw the provided 5/16" nuts (item 11) onto the threaded rod (item 9) so that they are inside the cut you will make. After the rod has been cut the nuts will help clean the threads. Cut the 5/16" threaded rod (item 9) to the proper length depending on axle type. See pictures below to determine rod length.

Axle Type 1

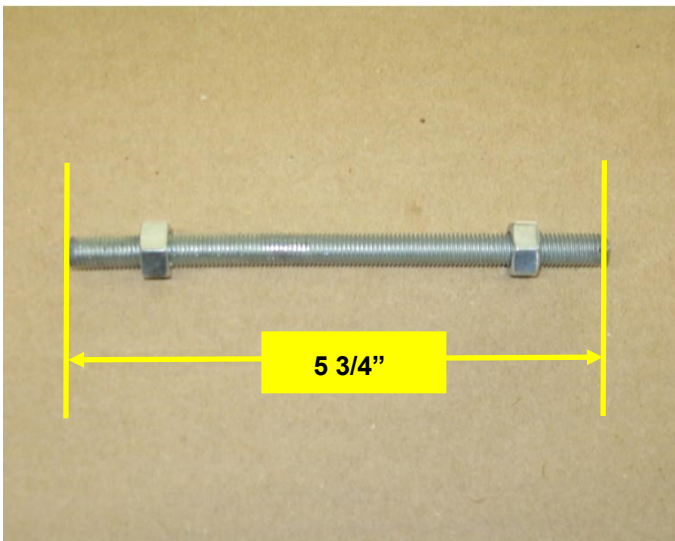

Figure 12

Axle Type 2

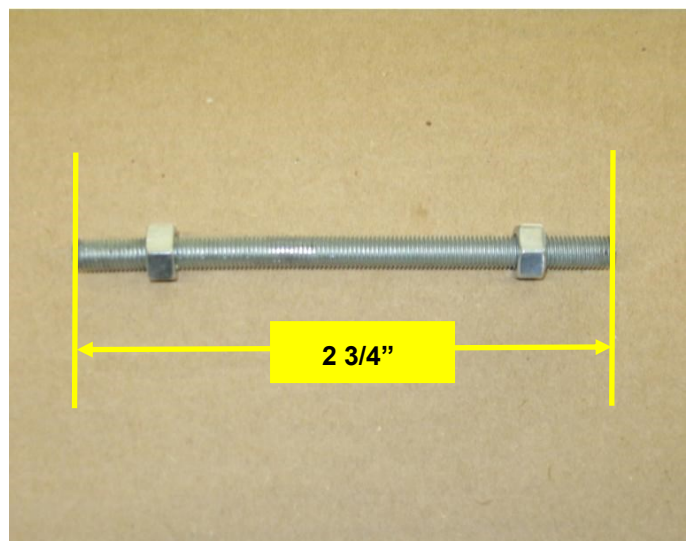

Figure 13

# Wheel Angle Sensor Installation

Screw the swivel rod ends (item 16) onto the cut threaded rod. The center to center stud measurement is dependent on which axle type your tractor has. Refer to the pictures below to determine which length to use. Leave the 5/16" nuts loose until you complete the WAS linkage installation.

Axle Type 1

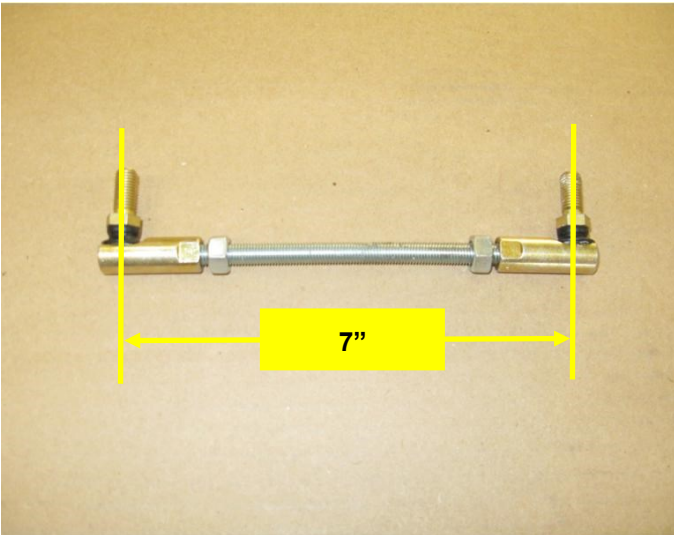

Figure 14

Axle Type 2

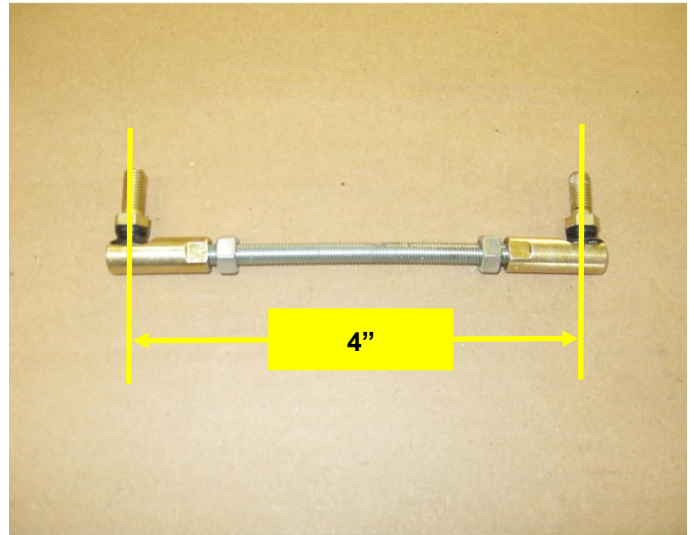

Figure 15

In the following section the photos are of the first axle type where the WAS mounting bracket bolt is close to the axle frame stop. If your tractor has the second axle type, mount the bracket accordingly.



Figure 16



# Wheel Angle Sensor Installation

Locate the top front axle bolt, next to the axle stop, on the right side of the tractor. Install the WAS mounting bracket (item 3) here.



Figure 17

Use the provided hardware (item 7), (item 10) and (item 13) to install the clamp (item 4) and rod mount (item 2) to the tie rod next to the lock nut.



Figure 18

Attach the WAS assembly to the mounting bracket (item 3) using hardware (item 8)



Figure 19



# Wheel Angle Sensor Installation

Install the assembled WAS linkage between the rod bracket (item 2) and the last hole in the WAS connector arm (item 1). Install the linkage with the swivel studs downwards but leave the swivel stud nuts loose.



Figure 20

With all hardware loose, slowly turn the wheels full left lock then full right lock pictured below. Check that the linkage moves freely without binding and adjust the linkage if necessary. When the linkage does move freely and without binding, tighten hardware on the rod and the swivels.

Full Left Lock



Figure 21

Full Right Lock



Figure 22

# Steering Encoder Terminating Plugs Installation

Next, install the steering wheel encoder termination plugs 051-0463-10 and 051-0464-10. These termination plugs are used to keep the tractor from displaying fault codes when turning the steering wheel.

Remove the 6 screws that hold the steering column shroud in place. There are 2 screws down each side. You will have to lift the floor mat up and out of the way to get to the bottom screws



Figure 23

The last 2 screws are on the front of the shroud.

On certain models, the air flow control knob may need to be removed to remove the bottom piece of the shroud.



Figure 24



# Steering Encoder Terminating Plugs Installation

Once all the plastic shroud pieces are removed, you will need to locate the steering wheel encoder connections. They are located on the bottom right side of the steering column.



Figure 25

The steering wheel encoder connections are pictured right.



Figure 26

# Steering Encoder Terminating Plugs Installation

Plug the 051 0463-10 and the 051-0464-10 termination plugs into the steering column encoder harness. It doesn't matter which terminator plug goes to which connector.



Figure 27

Take the other end of the steering encoder harness connection and connect 1 of the 2 ends to the 051-0496-10 harness. It doesn't matter which connector you plug into.

Secure the steering encoder connections up and out of the way to prevent damage to harnesses.



Figure 28



# Flowmeter Sensor

Locate the steering flowmeter installed on your tractor. It will either be near the battery box or on the left side of the engine under the hood.

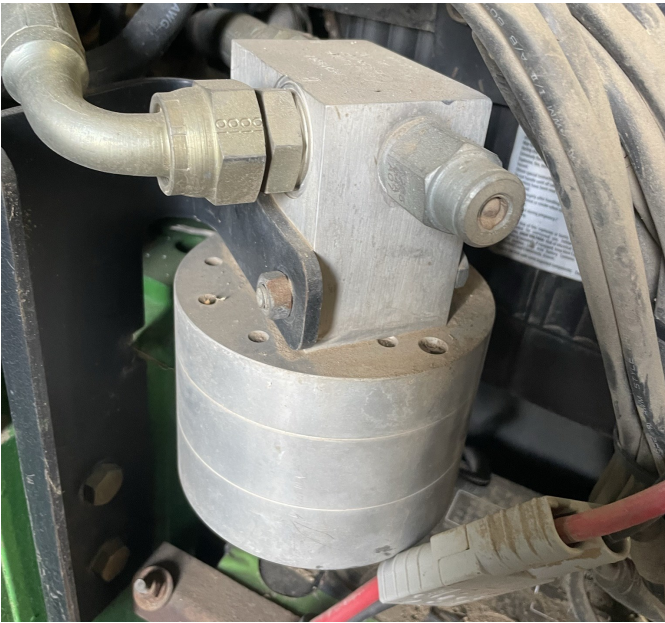

Figure 29

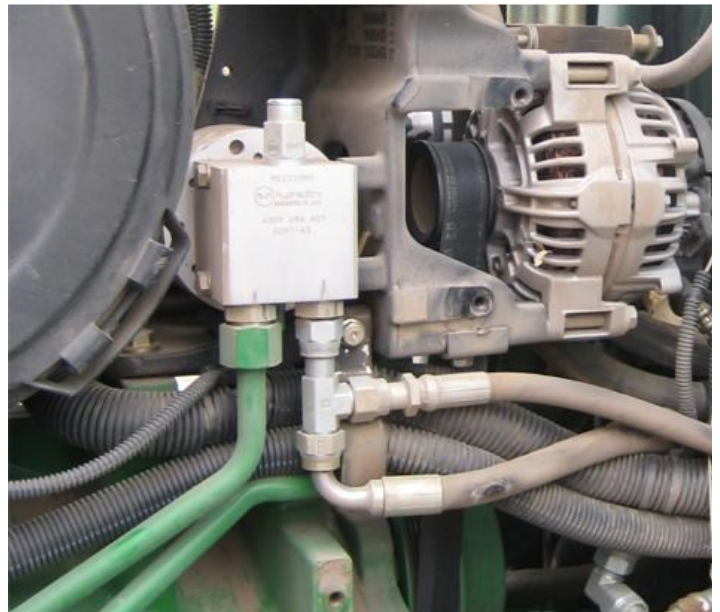

Figure 30

Remove the 2 allen screws holding the flowmeter sensor and remove the sensor from the housing. Leave the sensor plugged in and secure the sensor up out of the way with zips ties away from the flowmeter. This will allow the tractor to still see the sensor connected but not register any flow so no fault codes will be displayed.

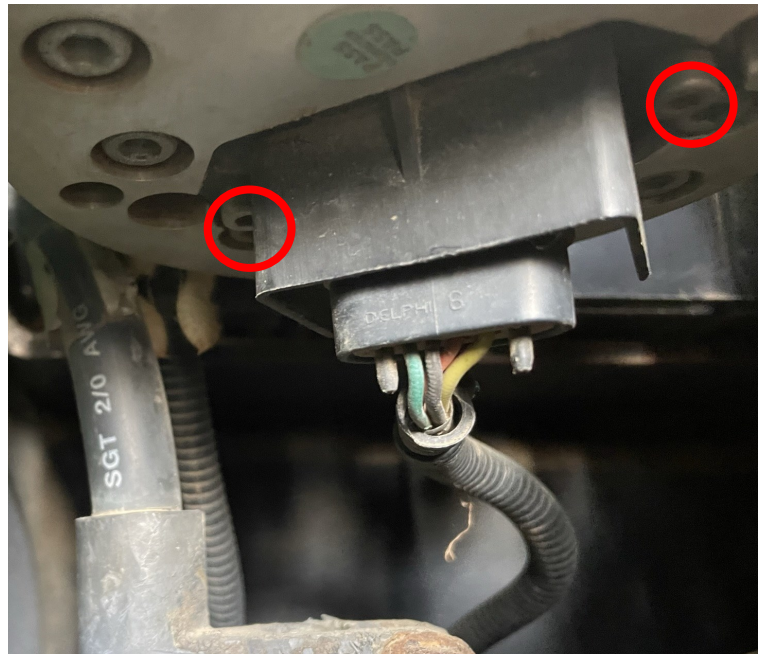

Figure 31

## Connecting to Autotrac PVE VALVE

---

Locate the PVE steering valve under the cab attached to the steering orbital.



Figure 32

Disconnect the machine's harness from the PVE valve and connect the 051-0462-10 harness to the PVE valve.

Connect all remaining harness ends per diagram figure 1 page 4

This concludes the cable connections for this install.



Figure 33

## Initial Setup

---

When creating a new machine in your Maverix terminal, you will need to select “Hyd. Ratiometric” for your machines valve type. To setup the disengage sensor you will use the “Automatic Detection” feature. This will calibrate the disengage sensor and select “Digital (Freq.)” as the correct disengage sensor for your machine.

## Troubleshooting & Diagnostics

**To read the voltage values coming from the factory wheel angle sensor and or disengage steering encoder, refer to the terminal user guide to see where to read sensor diagnostic information.**

### Wheel Angle Sensor

The wheel angle sensor has a voltage output range of 0-5 volts. You should be able to see the wheel angle voltage change as you turn the tractor from full left lock to full right lock. If the voltage doesn't go up or down when turning the steering wheel then there may be a problem with the wheel angle sensor.

### Steering Encoder Sensor

The factory Steering Encoder Sensor emits pulses used to disengage the machine. You should be able to see a number of pluses in the diagnostics screen increase when turning the steering wheel then the pulses should go to zero after the steering wheel is no longer turned.