

eDrive VSi Installation Guide

Kit: eDTC / eDX VSi - JDA400

P/Ns 911-1003-000 (TC), 911-4006-000 (eDX)

Fits John Deere Swather and Combine Models †:

Swathers *

A400 4895

R450 4995

D450

** eDTC only*

CTS Combines

9650 9750

9780

CTS CTS II

T-Series Combines

550 560

660 670

Combines

9400 9500 9600

9410 9510 9610

9450 9550 9650

C670

STS Combines

9650 9560 9570

9750 9660 9670

9760 9770

9860 9870

W-Series Combines

540 550

650 660



† Kit is for machines that have the steering column shown at far right.

Read and Follow Safety Messages

- In these instructions, you will see the heading **WARNING** and the safety alert symbol . They indicate a hazardous situation that, if not avoided, could result in death or serious injury. The safety messages provide information to identify a hazard associated with potential injury.
- Do not allow anyone to operate without instruction.
- Keep these instructions and all related safety information with the manuals for your machine and other implements.

If you have questions or need assistance, contact your local dealer or distributor.

Overview

This is a general guideline for the installation of the VSi electric steering wheel and either eDriveTC or eDriveX. Every effort has been made to verify the following installation procedure. However, due to the manufacturing process outside of AgJunction's control, the installer may have to adapt this kit to your distinct situation.

The items in the kits are detailed in the tables that follow the safety warnings on the next page. After the kit tables there are step-by-step installation instructions.

Please read this manual thoroughly before beginning the installation.

⚠ WARNING:

The VSi Electric Steering Wheel is designed as a driver aid for precision agriculture applications. At all times the driver is fully responsible for the safe operation of the vehicle. It is not intended for and must not be enabled for use on roadways.

⚠ WARNING:

To avoid serious injury or death during machine operation, install the appropriate kit for your make and model.

Machine Preparation

⚠ WARNING:

Inspect the machine and perform any needed maintenance before installing the VSi kit (for example, adjust the steering linkage so that the machine drives straight ahead without manual steering). This kit cannot perform as intended on a machine that is not maintained properly. Errors in performance increase the risk of operator and bystander injury or death.

Failure to maintain properly adjusted steering linkage can cause loss of directional control resulting in serious injury or death.

Turn off the machine and power off all components when installing or performing maintenance.



Before attempting to install any of the components:

- Park the machine on a clean level floor
- Ensure adequate clearance to work all around
- Lower all implements and headers to the ground
- Apply the park brake and chock the wheels

Before you perform any drilling, cutting or fastening, ensure that no other machine components, such as electrical wiring, will be damaged. Failure to follow this warning may cause physical injury and/or damage to the machine.

Kit Contents - eDriveTC and eDriveX

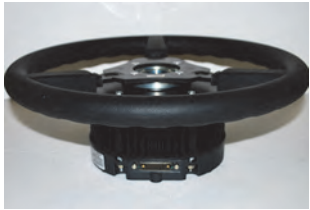
Unpack the supplied kit and identify the required parts as shown. Kit items, which are applicable to both VSi/eDriveTC and VSi/eDriveX installations, are referenced as A, B, C etc. with the item references being used in the step-by-step installation sections of this guide.

REF	PART NUMBER	QTY	DESCRIPTION	PHOTOGRAPH
A	750-8001-000	1	VSi steering wheel	
B		1	Shaft adapter (Use in A)	
C		4	Screw, M5 x 10 flat head socket cap screws (Attach B to A)	

Kit Contents - eDriveTC and eDriveX (continued)

REF	PART NUMBER	QTY	DESCRIPTION	PHOTOGRAPH
D		1	Anti-rotation (a/r) 'T' bar mounting bracket (Attach to A)	
E		3	Bolt, M6 x 16, hex head	
		3	Washer, spring (Attach D to A)	
F		1	Anti-rotation (a/r) 'T' bar (Attach to D)	
G		2	Bolt, M6 x 16, hex head	
		2	Washer, M6 flat	
		2	Nut, M6 nylock, flanged (Attach F to D)	
H1		1	Anti-rotation clamp (console) bracket, front	
H2		1	Anti-rotation clamp (console) bracket, rear	
H3		1	Anti-rotation pillow block mounting bracket	

Kit Contents - eDriveTC and eDriveX (continued)



REF	PART NUMBER	QTY	DESCRIPTION	PHOTOGRAPH
I			Anti-rotation pillow block	
J		4	Nut, M6, nylock, flanged (Attach H3 to H1 [2] and I to H3 [2])	
K		1	Protective, self-adhesive foam tape	
L		2	Bolt, M6 x 30, hex head	
		2	Washer, M6 flat	
		2	Nut, M6, nylock, flanged (Connect console clamps H1 and H2)	
M		1	Linchpin (Retains F)	
N		1	Special nut, 3/4NC (Attach steering wheel assembly [A] to steering shaft - replaces machine's original steering wheel nut)	
O		1	Column telescoping actuator	
P		1	Screw, M8 x 40 hex head	
		1	Washer, M8 spring	
		1	Column telescoping actuator plate (For inside column telescoping actuator)	
Q		1	Washer, M8 flat	
		1	Washer, M8 spring	
		1	Nut, M8 plain (For outside column telescoping actuator)	

Kit Contents - eDriveTC and eDriveX (continued)

REF	PART NUMBER	QTY	DESCRIPTION	PHOTOGRAPH
R		1	Steering wheel center cover	
S		1	Telescoping actuator center cap	
T	750-8003-000	1	VSi power cable	
U	750-8002-000	1	VSi junction box	
V		1	Junction box mounting bracket	
W	750-8005-000	1	CAN bus terminator	
X		1	Junction box comms cable clip	





Kit Contents - eDriveTC Only

Unpack the supplied kit and identify the required parts as shown. Kit items, which are applicable to VSi/eDriveTC installations only, are referenced as TA, TB and TC, with the item references being used in the step-by-step eDriveTC installation section of this guide.

REF	PART NUMBER	QTY	DESCRIPTION	PHOTOGRAPH
TA	054-0044-003	1	Power cable, eDriveTC	
TB	051-0259-000	1	CAN bus harness, eDriveTC (The 'CAN cable')	
TC	806-1007-03A	1	ECU, eDriveTC	

Kit Contents - eDriveX Only

Unpack the supplied kit and identify the required parts as shown. Kit items, which are applicable to VSi/eDriveX installations only, are referenced as EA, EG, EJ etc. (from ECU - see Notes after EA and EGa) with the item references being used in the eDriveX step-by-step installation section of this guide.

REF	PART NUMBER	QTY	DESCRIPTION	PHOTOGRAPH
EA	051-0226-000#	1	Main cable	
Note: Items EB to EF are not used in this installation				
EG	054-0117-000	1	Power switch (Use EGa to mount if necessary)	
EGa	726-1093-000	1	Switch bracket (Mount EG, if required)	
Note: Items EH and EI are not used in this installation				
EJ	640-0091-000	1	ECU (EK) mounting bracket	
EK	806-1031-000	1	ECU, eDriveX	

Kit Contents - eDriveX only (continued)

REF	PART NUMBER	QTY	DESCRIPTION	PHOTOGRAPH
Bag E1 of 1 contains EL, EM and EN				
EL	675-1197-000	4	Screw, self-drilling, #10-16 x 2-1/2", hex, ZP (Attach EJ to cab floor - or use EM)	
EM	675-1192-000	4	Screw, self-drilling, #10-16 x 3", hex, ZP (Attach EJ to cab floor - or use EL)	
EN	675-1188-000	4	Screw, mach, M6 x 12mm, PPH, ZP (Attach EK to EJ)	
EO	051-0316-000	1	CAN bus harness - eDriveX	
EP	677-2002	20	Tie straps, 7" releasable	
EQ	051-0304-000#	1	Power cable - long (combines only) (eDriveX only)	

eDrive VSi Installation Procedure

NOTE:

On a clean surface lay out all the components and check them against the “Kit Contents - eDriveTC and eDriveX” on page 2. Become familiar with the components and where they are to be installed before proceeding with the installation (see “Appendix A - eDriveTC VSi Connections” on page 17 or “Appendix B - eDriveX VSi Connections” on page 18).

1. Prepare the VSi electric steering wheel.

- a. Place the VSi steering wheel assembly **A** on a clean surface with the wheel facing up. Insert shaft adapter **B** into steering wheel **A** (Figure 1a).

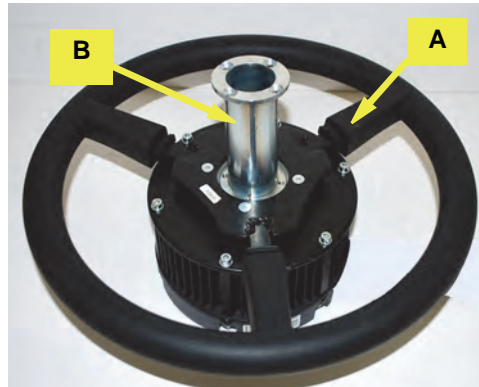

Figure 1a: Inserting shaft adapter into steering wheel



At step 1b following, tighten the screws to the specified torque only. **DO NOT OVERTIGHTEN - DAMAGE MAY OCCUR.**

- b. Using the four countersunk screws **C**, secure the shaft adapter **B** in the steering wheel. Torque the screws to **6 N·m (53 in-lb)** (Figure 1b).

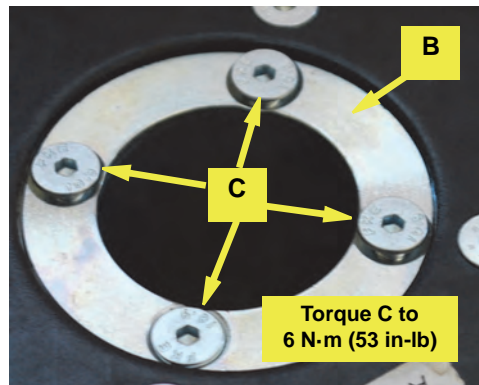

Figure 1b: Securing the shaft adapter

2. Install the anti-rotation ‘T’ bar.



When completing this step, ensure that you (i) use only the bolts provided, (ii) use the washers provided and (iii) tighten the bolts only until the spring washers are compressed, that is, to no more than the specified torque. **DO NOT OVERTIGHTEN OR OMIT WASHERS - DAMAGE WILL OCCUR.**

Using hardware **E**, attach the anti-rotation ‘T’ bar mounting bracket **D** to the base of the steering wheel assembly on the same side as the communications port (Figure 2a-i - **F** shown installed already). Using hardware **G** attach ‘T’ bar **F** to **D**. Torque all fasteners to **8 N·m (71 in-lb)** (Figures 2a-i and 2a-ii).

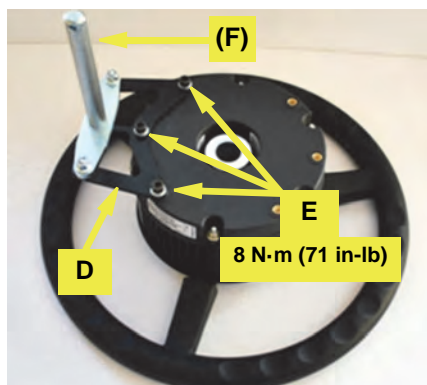

Figure 2a-i: Installed ‘T’ bar mounting

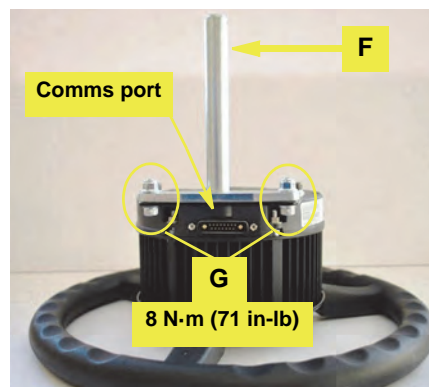

Figure 2a-ii: Installed ‘T’ bar

3. **Assemble the anti-rotation pillow block and clamp brackets.**

a. Using flanged nuts **J**, mount the pillow block mounting bracket **H3** to the front console clamp **H1** (Figure 3a).

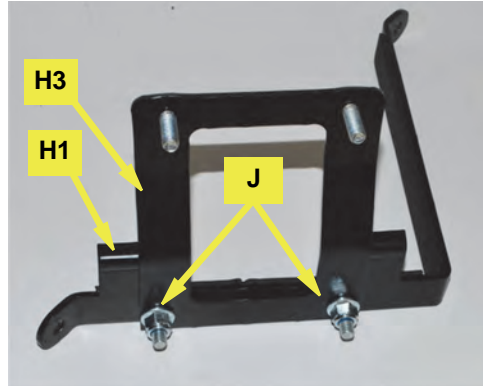

Figure 3a: Pillow block mounting bracket on front clamp bracket

b. Using flanged nuts **J**, mount the pillow block **I** on its mounting bracket **H3** (Figure 3b).

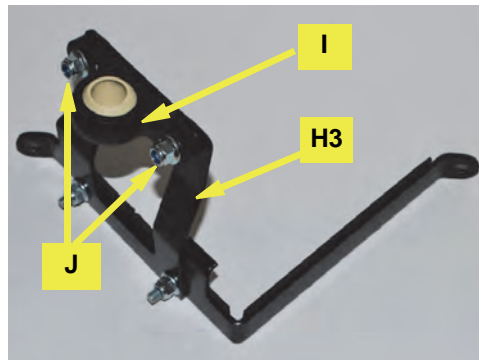

Figure 3b: Pillow block on mounting bracket (on front clamp bracket)

c. Place self-adhesive protective foam tape **K** (not shown) on the inside of the console clamp brackets **H1** and **H2**. Using hardware **L**, loosely and evenly connect the front and rear brackets (Figure 3c and inset).

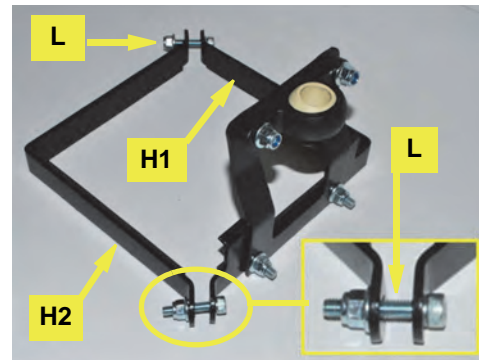

Figure 3c: Connected front and rear clamp brackets

4. **Remove the machine's steering wheel.**

Remove the steering wheel center cap and the steering wheel retaining nut (Figure 4 insets) and remove the steering wheel (Figure 4).

NOTE:

Consult your equipment dealer if you are unsure of the correct procedure for removing the steering wheel.

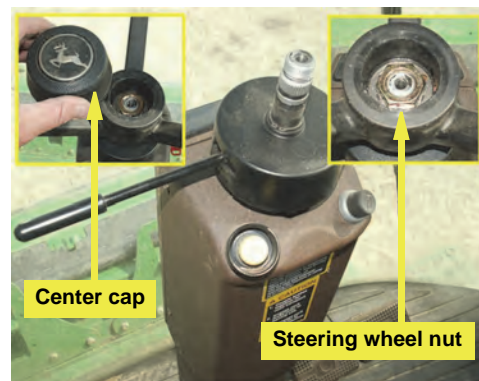

Figure 4 with insets: Steering wheel removal

5. **Install the anti-rotation column clamp bracket assembly.**

With the pillow block at the front of the steering column, lower the column clamp assembly over the steering column until the lugs on **H1** rest on the top of the steering column (Figure 5 with inset).

Tighten the two sets of corner fasteners **L** evenly (so the gaps are the same) to **8 N·m (71 in-lb)**

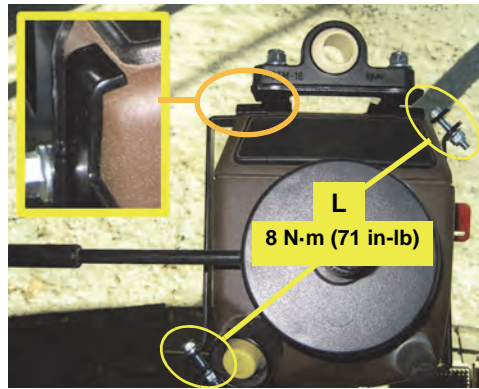

Figure 5 with inset: Column clamp assembly installed on column

6. **Install the VSi steering wheel assembly.**

Apply a small amount of an anti-seize compound (not supplied) to the splines of shaft adapter **B**, then, carefully aligning **B**'s splines with those on the steering shaft, slide the steering wheel assembly onto the shaft while guiding the 'T' bar shaft into the pillow block bushing. Insert and lock linchpin **M** (not shown) (Figure 6).

Use the special nut **N** (not shown) to secure the steering wheel assembly on the steering shaft. Consult your John Deere dealer for the correct torque specification.

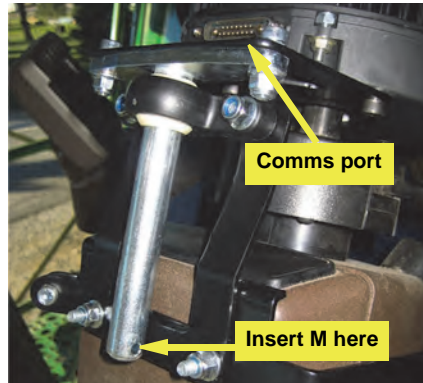

Figure 6: Steering wheel assembly installed

7. **Install the column telescoping actuator.**

- a. Insert hardware **P** into the telescoping actuator **O**. The slotted washer is last on the cap screw and its slots must align with the ribs in the base of the actuator (Figure 7a with inset).

Add hardware **Q** onto **P**'s screw at the bottom of the actuator. Tighten to **15 N·m (133 in-lb) only** (Figure 7a). **DO NOT OVERTIGHTEN**

- b. Snap the steering wheel center cover **R** into place (Figure 7b) and thread the telescoping actuator assembly into place in the center of the steering wheel (Figure 7b, left inset). Telescoping movement is now enabled.

- c. Install the center cap **S** (Figure 7b, right inset).

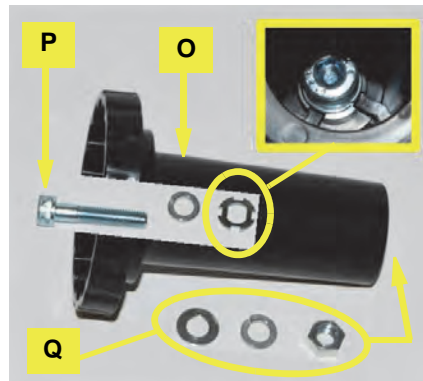

Figure 7a: Assembling the telescoping actuator

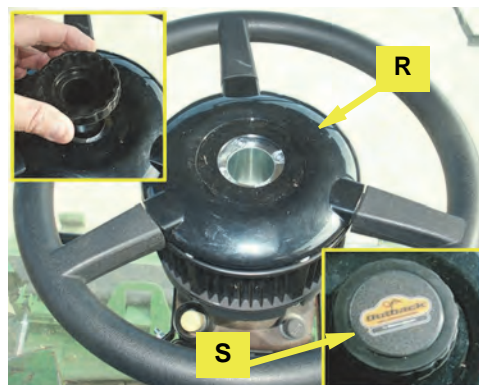



Figure 7b with insets: Installed center cover, telescoping actuator and center cap

8. **Install and connect the electric steer junction box.**

NOTE: Before continuing, refer again to “Appendix A - eDriveTC VSi Connections” on page 17 or “Appendix B - eDriveX VSi Connections” on page 18.

- a. Route the power supply cable **T** from the battery into the cab to where you will mount the junction box **U** at steps 8b and 8c. Ensure the cable will not be a trip hazard. Connect the ring terminals to the battery (not shown).

 When mounting junction box **U** in the following steps, ensure that its ON/OFF switch is within easy reach of the operator. See Figure 8a. The switch must be in the OFF position when the vehicle is not under field guidance or on a road.

Ensure that the mounted junction box cannot interfere with movement of the steering column or visibility to the work area. Also keep in mind the location of the steering wheel assembly’s comms port.

- b. Mount the junction box bracket **V** (not shown) on the steering column or windscreen using your preferred method, for example fasteners, double-sided tape, nylon ties (not provided).

 If drilling the steering column, ensure nothing inside the column can be damaged.

- c. Clip the junction box **U** into place on its bracket **V** (neither shown) then connect **U**’s 15-pin connector cable to the communications port on the steering wheel assembly (Figure 8b). Use clip **X** suitably (not shown).
- d. Connect the gray connector of the power cable **T** (routed into the cab at step 8a) to the gray cable from the junction box **U** (Figure 8c).

- e. Connect the threaded 5-pin connector on the CAN bus harness **TB** (eDriveTC) or **EO** (eDriveX) to either of the threaded connectors on the junction box **U**. Connect the CAN bus terminator **W** to the other threaded connector on the junction box (Figure 8d).

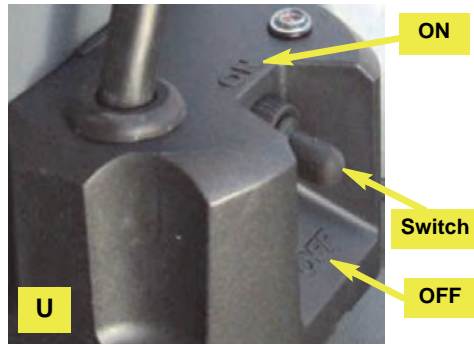

Figure 8a: Junction box ON/OFF switch - within easy reach of the operator

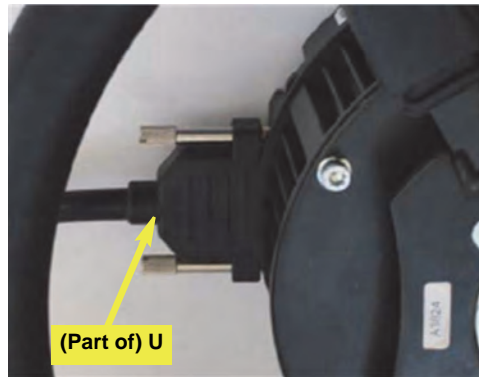

Figure 8b: Junction box comms cable connected to steering wheel assembly



Figure 8c: Power cable to junction box cable

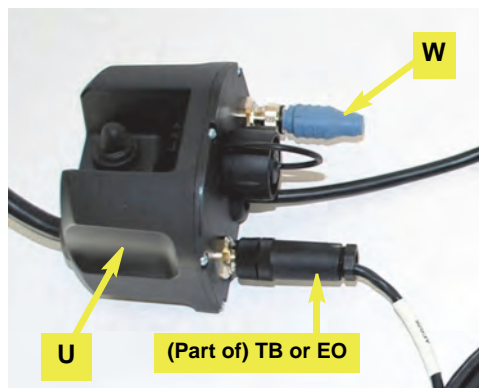

Figure 8d: CAN harness and terminator connected to junction box

8. **Install and connect the electric steer junction box (continued).**

f. **eDriveTC:** Route CAN cable **TB** to the terminal (MAX or STX) and the eDriveTC ECU **TC** (Figure 8e-i). For further connection information, see step 1c of “Installation - Electronic Control Unit (ECU) - eDriveTC” on page 14.

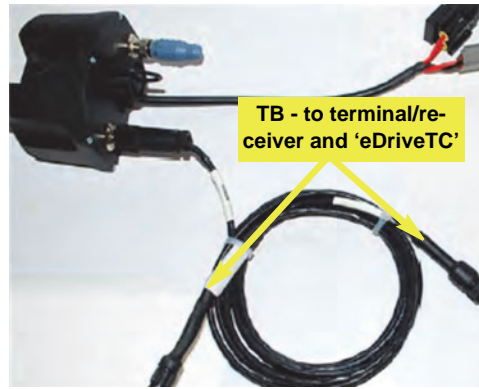

Figure 8e-i: CAN cables to eDriveTC and terminal/receiver

eDriveX: Route CAN cable **EO** to the eDriveX ECU's main cable, **EA** (Figure 8e-ii). For further connection information, see step 2b of “Installation - Electronic Control Unit (ECU) - eDriveX” page 16.



Figure 8e-ii: CAN cable to eDriveX

Installation - Electronic Control Unit (ECU) - eDriveTC

NOTE:

The guidance capability of eDriveTC depends, in part, on the installation of the ECU as detailed in this section.

⚠ WARNING:

Before drilling (or using self-drilling screws) in the cab, make sure there is nothing that can be damaged by the drilling or any self-drilling screws used to secure the ECU mounting bracket. Secure anything that could be damaged away from where the screws come through. See Figure 1 for an example of a pre-drilling check; it shows an under-floor cabling compartment.



Figure 1: Example pre-drilling check

1. Install the ECU.

- a. Through its end flanges, install the ECU **TC** on a level surface in the machine's cab. The unit must be 'UP' (see label), parallel to the fore/aft centerline of the machine, and pointing forward as indicated by the yellow label (Figure 1a). (The power switch and cable connectors will be inward with the unit installed on the right side of the cab.)
- b. Install power cable **TA** between the PWR IN port on the ECU **TC** and the machine's battery (Figure 1b with inset).
- c. Routing cables suitably, complete CAN cable **TB*** connections as follows (*connected to the VS_i junction box at step 8e):
 - Connect **TB**'s branch cable labeled "eDriveTC" to the CAN port on the ECU **TC** (Figure 1c with inset)
 - Connect **TB**'s remaining branch cable to your terminal's cable labeled either 'eDriveX' (MAX) or 'EDRIVE' (STX)

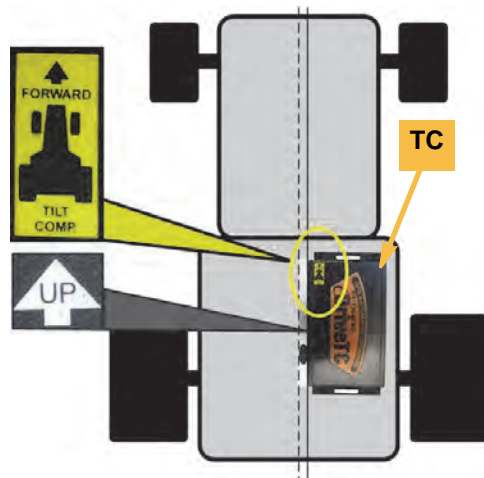

Figure 1a: ECU mounting location



Figure 1b with inset: Power cable connection at ECU



Figure 1c with inset: CAN cable connection at ECU

Installation - Electronic Control Unit (ECU) - eDriveX

NOTE:

The high precision guidance capability of eDriveX depends, in part, on the exact installation of the ECU as detailed in this section. This installation section is for combines only.

⚠ WARNING:

Before drilling (or using self-drilling screws) in the cab, make sure there is nothing that can be damaged by the drilling or any self-drilling screws used to secure the ECU mounting bracket. Secure anything that could be damaged away from where the screws come through. See Figure 1 for an example of a pre-drilling check; it shows an under-floor cabling compartment.

1. Install the ECU (combines only).

NOTE:

Although measurements and floor mat references provide an accurate guide, ensure that when installed, the bracket will be perpendicular to the front of the machine (that is, parallel to the machine's fore/aft centerline). Also, use a small level to set the bracket as level as possible - see steps following.

- a. Drill a 9/32" hole 3½" from the front edge of ECU mounting bracket **EJ** in line with the front outer hole (Figure 1a inset).
- b. Place bracket **EJ** on the floor to the right of the driver's seat with its one-inch tabs toward the seat. Set the bracket parallel to the machine's fore/aft centerline with (Figure 1a):
 - The inside edge of its one-inch tabs 2" from the base of the molded seat mount.
 - Its front edge 4" back from a line projected sideways from the front edge of the molded seat mount (note that the front outer screw hole in **EJ** is not on the surface of the molded seat mount).

NOTE:

At the next step, do not overtighten the self-drilling screws. Overtightening could cause the fastener to fail.

Using self-drilling screws **EL** or **EM** (depending on the floor thickness - see warning above) fasten the bracket to the cab floor (Figure 1b). Use a small level (not shown) to check the level of the bracket. Adjust accordingly.

- c. Using screws **EN** (not visible) attach the ECU **EK** to the front face of bracket **EJ**. Have the wire connections toward the rear and the power and communications indicators at the top (Figure 1c).



Figure 1: Example pre-drilling check

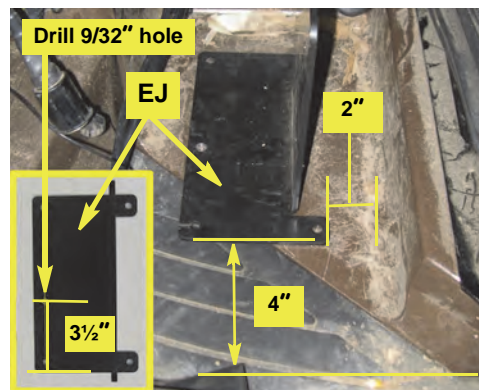

Figure 1a with inset: Preparing ECU mounting bracket and mounting location

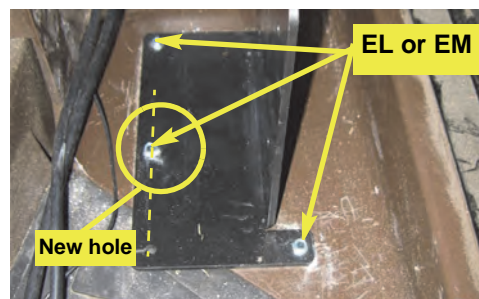

Figure 1b: ECU mounting bracket installed

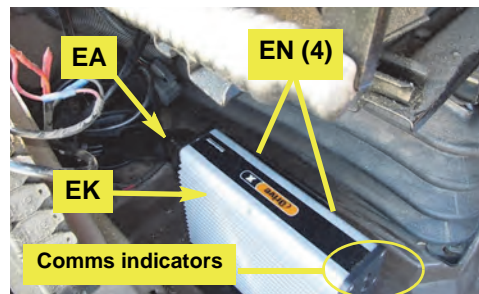

Figure 1c: Main cable connected to ECU

2. Assemble and install the cables.

On a clean surface lay out all the cables and become familiar with the connections and where they are to be placed. See “Appendix B - eDriveX VSi Connections” on page 18. Use cable ties **EP** as required.

- a. Connect cable **EA** to the ECU **EK** using an Allen wrench to secure the cable. The **EA** connector will only fit the ECU socket that is in line with the power and communications indicators at the opposite end of the ECU—the top socket in this installation (Figure 1c).
- b. Routing cables suitably, attach cable **EA**'s connector labeled ‘STEERING CONTROLLER’ to cable **EO** (connected to the VSi junction box at step 8f, page 13).
- c. Attach power switch **EG** to **EA**'s connector labeled ‘SWITCH’. Some machines are equipped with pop out tabs that you can remove and replace with switch **EG**. If no tab is available, you can use bracket **EGa** mounting it in the cab at the operator's preferred location.

NOTE:

Set switch EG to OFF before connecting EA to the battery at step e below.

- d. On your terminal (MAX/STX) cabling, locate the connector labeled ‘eDriveX’ (MAX) or ‘EDRIVE’ (STX). Connect (either) to **EA**'s connection labeled ‘TERMINAL/RECEIVER’. Route all cables in the cab so that they are clear of any machine operation controls.



Ensure you have connected main cable EA to the ECU (step 2a) and reconnected EA's power cable (after routing in/out of the cab) before you connect the machine's battery at the next step.

- e. Disconnect the standard length power cable from ECU main cable **EA** and connect the extended power cable **EQ**. Route **EQ** to the machine's 12V battery and connect it.

© Agjunction Inc. (2013). All rights reserved

Appendix A - eDriveTC VSi Connections

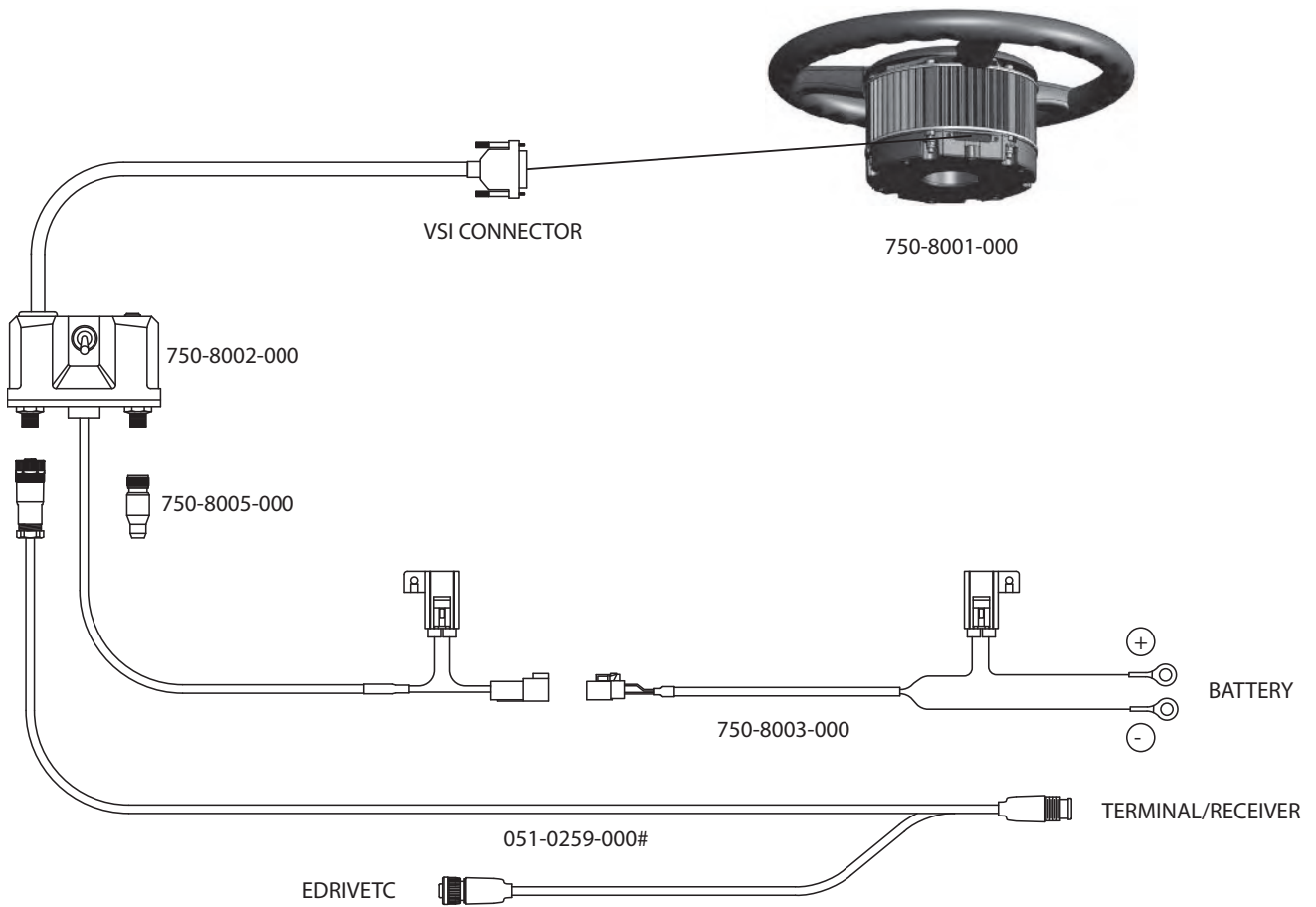

Appendix B - eDriveX VSi Connections

