

Automated Steering Kit Installation Guide

Kit: EDX-MXTX, P/N 911-2040-000

Fits CaseIH and McCormick Model Tractors:

MX100	MTX120	XTX185	ZTX230
MX110	MTX135	XTX200	ZTX260
MX120	MTX150	XTX215	ZTX280
MX135	MTX165		
MX150	MTX185		
MX170	MTX200		



Read and Follow Safety Messages

- In these instructions, you will see the heading **WARNING** and the safety alert symbol . They indicate a hazardous situation that, if not avoided, could result in death or serious injury. The safety messages provide information to identify a hazard associated with potential injury.
- Before installing, operating, or performing maintenance or service on any part of the system:
 - Read and understand this installation guide and all of the safety information.
 - Read and understand the Automated Steering System User Guide.
- Do not allow anyone to operate without instruction.
- Keep these instructions and all related safety information with the manual for your machine and other implements.

If you have any questions or need assistance, contact your local dealer or distributor.

Overview

A series of equipment specific kits has been developed to work in conjunction with your automated steering system. For the machine models listed above, these kits contain the components for:

- the steering hydraulics
- the wheel angle sensor (WAS)
- the steering wheel switch (SWS - for steering override)
- the electronic control unit (ECU)

The items in each kit are detailed in the tables that follow the safety warnings on the next page. After the kit tables, there are four step-by-step installation sections, one for each of the kits.

Please read this manual thoroughly before beginning the installation.

⚠ WARNING:

To avoid serious injury or death during machine operation, install the appropriate kits for your machine make and model.

Machine Preparation

⚠ WARNING:

Inspect the machine and perform any needed maintenance (for example, contaminated hydraulic fluid) before installing the automated steering kit. This kit cannot perform as intended on a machine that is not maintained properly. Errors in performance increase the risk of operator and bystander injury or death.

Failure to maintain clean hydraulic fluid and operational hydraulic components can cause loss of directional control resulting in serious injury or death.

To avoid serious injury, wear hand and eye protection and use wood or cardboard when checking for leaks.

Turn off the machine and power off the automated steering controller when installing or performing maintenance.





Before attempting to install any of the components, park the machine on a clean level floor with adequate clearance to work all around.

Before you perform any drilling, cutting or fastening, ensure that no other machine components, such as hydraulic hoses or electrical wiring, will be damaged. Failure to follow this warning may cause physical injury and/or damage to the machine.







To prevent hydraulic system contamination, it is essential to thoroughly clean hydraulic system fittings and hose connections prior to disconnecting or removing. Use a degreasing solvent spray cleaner such as a brake cleaner to prevent hydraulic system contamination. Note that o-rings used on ORB and ORFF type fittings, referred to in the Kit Contents section, may be damaged by degreasing solvent cleaners. If a fitting is to be cleaned internally, you should first remove and clean the o-ring with a fiberless cloth.

Kit Contents - Steering Hydraulics

Unpack the hydraulics installation kit and identify the required parts as shown. Kit items are A, B, C etc. with an H (Hydraulic) prefix.

REF	PART NUMBER	QTY	DESCRIPTION	PHOTOGRAPH
HA	760-0020-000	1	Assembly, hyd valve block - 15L\proportional (Hydraulic steering block)	
Bag H1 of 8 contains HB, HC and HD				
HB	760-2061-000	2	Adapter, hyd 90 elbow - #6maleJIC x #8maleORB (P [pressure] and T [tank] ports on hydraulic steering block)	
HC	760-2060-000	2	Adapter, hyd - #6maleJIC x #8maleORB (A and B steering ports on hydraulic steering block)	
HD	760-2058-000	1	Adapter, hyd 90 elbow - #6maleJIC x #8maleORB (LS port on hydraulic steering block)	









Kit Contents - Steering Hydraulics (continued)

REF	PART NUMBER	QTY	DESCRIPTION	PHOTOGRAPH
HE	640-0122-000	1	Hydraulic steering block mounting bracket	
Bag H2 of 8 contains HF				
HF	675-2003-000	2	Bolt - 3/8NC x 1" Gr5, ZP	
	678-1054-000	2	Washer, flat - 3/8, ZP	
	676-1035-000	2	Nut, nylock - 3/8NC, ZP	
(Mount HE on machine - if required, MX)				
Bag H3 of 8 contains HG				
HG	675-2006-000	2	Bolt - 3/8NC x 3-3/4" Gr5, ZP	
	678-1054-000	2	Washer, flat - 3/8, ZP	
	676-1035-000	2	Nut, nylock - 3/8NC, ZP	
(Mount HA on HE)				
HH	760-0001	1	Assembly, hyd - counterbalance valve, reactive	
Bag H4 of 8 contains HI				
HI	675-2020	2	Bolt, 1/4NC x 2" Gr5, ZP	
	678-1053	2	Washer, flat - 1/4", ZP	
	676-1034	2	Nut, lock - 1/4NC, ZP	
(Mount counterbalance valve)				
HJ	640-0063-000	1	Steering controller mounting bracket	

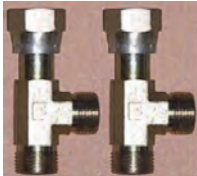
Kit Contents - Steering Hydraulics (continued)











REF	PART NUMBER	QTY	DESCRIPTION	PHOTOGRAPH
HK	750-5003-000	1	Steering controller	
Bag H5 of 8 contains HL				
HL	675-2002	2	Bolt, 1/4NC x 2-1/2" Gr5, ZP	
	678-1053	2	Washer, flat - 1/4", ZP	
	676-1034	2	Nut, lock - 1/4NC, ZP	
(Mount steering controller HK on bracket HJ)				
Bag H6 of 8 contains HM and HN				
HM	760-2069	2	Adapter, hyd run-tee - #8ORFF (Pressure and tank ports in orbital)	
HN	760-2070	2	Adapter, hyd 90 elbow - #8maleORFF x #8femORFF (Use with HM if necessary - see steps)	
HO	760-0009	1	Assembly, hyd dynamic load sense valve	
Bag H7 of 8 contains HP, HQ, HR and HS				
HP	760-2033	1	Adapter, hyd - #4maleORFF x #6maleORB (Source port in HO)	
HQ	760-2090	1	Adapter, hyd - #6maleORB x #4femORB (Function port in HO - use with HR)	
HR	760-2089	1	Adapter, hyd 90 elbow - #4maleORB x #4femORFF (Use with HQ)	
HS	760-2082	1	Adapter, hyd 90 elbow - #6maleJIC x #4maleORB (LS port in HO - to hydraulic steering block)	

Kit Contents - Steering Hydraulics (continued)





REF	PART NUMBER	QTY	DESCRIPTION	PHOTOGRAPH
Bag H8 of 8 contains HT, HU and HV				
HT	760-2080	2	Adapter, hyd 90 elbow - #8maleJIC x #8maleORB (Counterbalance valve 'V' ports)	
HU	760-2083	2	Adapter, hyd - #8maleORFF x #8maleORB (Counterbalance valve 'C' ports - use with HV)	
HV	760-2069	2	Adapter, run-tee - #8ORFF (Use with HU in counterbalance valve 'C' ports)	
HW	760-1256	2	Hose, hyd - 1/2" x 28", #8femJIC swivel x #8femORFF swivel (Steering hoses - counterbalance valve 'V' ports to/from orbital)	
HX	760-1123	2	Hose, hyd - 3/8" x 40", #6femJIC swivel x #8femORFF 90 swivel (Steering hoses - HVs in counterbalance valve to/from HA)	
HY	760-1267	2	Hose, hyd - 3/8" x 40", #6femJIC 90 swivel x #8femORFF swivel (Pressure and tank hoses - orbital to/from HA)	
HZ	760-1077	1	Hose, hyd - 1/4" x 36", #6femJIC swivel both ends (Load sense hose - orbital to/from HA)	
Ha	677-2001	20	Tie strap, 11" heavy duty	

Kit Contents - Wheel Angle Sensor

Unpack the wheel angle sensor kit and identify the required parts as shown. Kit items are A, B, C etc. with a W (Wheel) prefix.





REF	PART NUMBER	QTY	DESCRIPTION	PHOTOGRAPH
Bag 710-0099-000 (W1 of 3) contains WA to WF				
WA	720-0045-000#	1	WAS assembly	
WB	750-5002-000	1	Sensor, dual output, BEI (‘Wire connector’)	
WC	602-1087-000	1	Connector arm, steering	
WD	675-1191-000	2	Screw, mach, 8-32 x 3", PPH, ZP	
WE	676-1054-000	3	Nut, nylock 8-32NC, ZP	
WF	675-1150-000	1	Screw, 8-32 x 1", Allen socket cap, ZP	
WG	675-2031-000	1	Threaded rod, 5/16-24 x 12"	
Bag W2 of 3 contains WH, WI and WJ				
WH	676-1053-000	4	Nut, 5/16-24 standard, ZP	
WI	760-0018-000	2	Rod end swivel with stud, 5/16-24	
WJ	675-2010	2	Bolt, 5/16NC x 3/4" Gr5, ZP (Attach WAS assembly to WK)	

Kit Contents - Wheel Angle Sensor (continued)

REF	PART NUMBER	QTY	DESCRIPTION	PHOTOGRAPH
WK	640-0148-000	1	WAS assembly mounting bracket (You will modify this bracket slightly for ZTX machines)	
WL	640-0070-000	1	WAS link rod bracket	
Bag W3 of 3 contains WM and WN				
WM	675-0106-000	2	Clamp, 1-1/4" polypropylene (Attach WL to tie rod with WN)	
WN	675-2005-000	2	Bolt, 3/8NC x 3-1/4" Gr5, ZP	
	676-1035-000	2	Nut, nylock 3/8NC, ZP	
	678-1054-000	2	Washer, 3/8" narrow flat, ZP (Attach WL to tie rod with WM)	

Kit Contents - Steering Wheel Switch

Unpack the steering wheel switch kit and identify the required parts as shown. Kit items are A, B, C etc. with an S (Switch) prefix.

REF	PART NUMBER	QTY	DESCRIPTION	PHOTOGRAPH
SA	478-0008	2	Magnet, flex - 1/2" W x 1" L x 1/8" thk, plain 1 (Only one required for this installation)	
SB	675-0077	1	Epoxy, Hardman 04001 - single double bub	
SC	602-1062	1	Bracket, steering wheel switch mounting	
SD	726-1054	1	Assembly, steering wheel switch/cable	
SE	677-2002	4	Tie strap, 7" releasable	

Kit Contents - Electronic Control Unit

Unpack the electronic control unit kit and identify the required parts as shown. Kit items are A, B, C etc. with an E (Electronic) prefix.

REF	PART NUMBER	QTY	DESCRIPTION	PHOTOGRAPH
EA	051-0226-000#	1	Main cable	
EB	054-0115-000#	1	Steering controller extension cable	
EC	051-0228-000#	1	Steering controller main cable	
ED	051-0231-000#	1	Valve cable	
EE	051-0230-000#	1	WAS cable	
EF	051-0229-000#	1	SWS cable	

Kit Contents - Electronic Control Unit *(continued)*

REF	PART NUMBER	QTY	DESCRIPTION	PHOTOGRAPH
EG	054-0117-000#	1	Power switch (Use EGa to mount if necessary)	
EGa	726-1093-000	1	Switch bracket (Mount EGa, if necessary)	
EH	051-0166-000#	1	CAN-PWR cable	
EI	806-1031-000#	1	Controller (ECU)	
EJ	640-0091-000	1	ECU mounting bracket	
Bag E1 of 1 contains EK and EL				
EK	675-1192-000#	4	Screw, self-drilling, #10-16 x 3", hex, ZP	
EL	675-1188-000	4	Screw, mach, M6 x 12mm, PPH, ZP	

Installation - Automated Hydraulic Steering Kit

⚠ WARNING:

Before installing, disconnecting or repairing the hydraulic hoses and components, turn off the machine and relieve all pressure from the hydraulic system by turning the steering wheel left and right. Failure to remove the pressure can result in serious injury or death from unexpected machine movement.

To avoid burn injury when installing, disconnecting or repairing the hydraulic hoses and components, turn off the machine and allow the system to cool down prior to touching the parts of the machine that are heated.

See Appendix B for a schematic of the hydraulic circuits.

1. Prepare the hydraulic steering block.

NOTE: Make sure the hydraulic steering block **HA** is clean and dust free.

Remove the plastic plugs from hydraulic steering block **HA** and install adapter fittings as follows (Figure 1):

- **HB** in the **P** and **T** ports
- **HC** in the **A** and **B** ports
- **HD** in the **LS** port

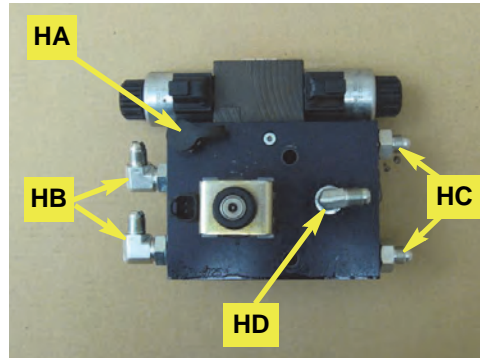

Figure 1: Prepared hydraulic block

2. Install the steering block mounting bracket.

NOTE: The hydraulic steering block mounting bracket is installed slightly differently for different models covered by this installation guide. Follow step 2a or 2b accordingly.

- a. **MTX and XTX:** Locate the two bolts in the muffler shield on the right side of the machine. Using those bolts, install hydraulic steering block mounting bracket **HE**. Mount **HE** with its long side outward (Figure 2a with inset).

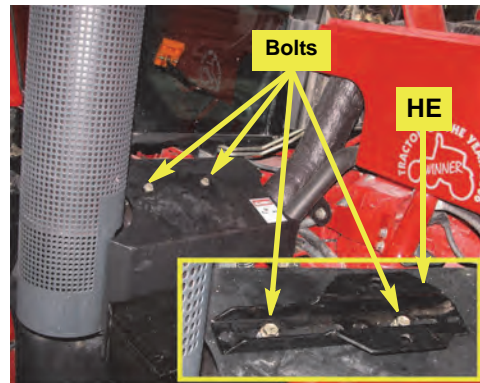

Figure 2a with inset: Steering block mounting bracket location and (inset) installed (MTX/XTX)

- b. **MX:** Locate the shield above the exhaust pipe on the right side of the machine in front of the cab. Drill a 7/16" hole 1-3/4" from the front inner angle of the shield and 1/2" from the front edge. Using the steering block bracket **HE** as a template, drill a second 7/16" hole parallel to the front edge of the shield (Figure 2b).

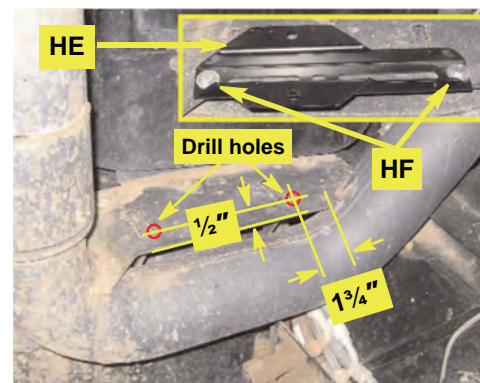

Figure 2b with inset: Steering block mounting bracket location and (inset) installed (MX)

3. **Install the hydraulic steering block and steering controller mounting bracket.**

Using hardware **HG**, attach hydraulic steering block **HA** and steering controller bracket **HJ** to bracket **HE** as follows (Figure 3 - MTX/XTX installation shown):

- Mount **HJ** on **HE** with its short side forward and pointing upward. (Set **HJ** forward on its slots to create some cable storage space).
- Mount **HA** with its L/R solenoids toward the cab (so with **P** and **T** ports outward).

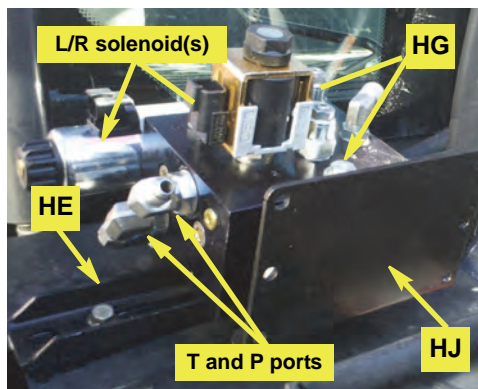

Figure 3: Steering block and steering controller bracket installed (MTX/XTX)

4. **Prepare, install and partially connect the counterbalance valve.**

NOTE: Route all hoses with other machine plumbing free from entanglement and secured with heavy tie straps **Ha**. Securely tighten all hose fittings and connections when hose installation is complete.

a. Prepare counterbalance valve **HH** by installing adapter fittings as follows (Figure 4a):

- **HT** in the valve's 'V' ports
- **HU** in the valve's 'C' ports
- **HV** on adapters **HU**

b. Using counterbalance valve **HH** as a template, drill two 5/16" holes in the outer face of the left hood support slightly below the upper bend in the support (Figure 4b).

Using hardware **HI** (not shown) mount the counterbalance valve on the inside of the hood support with the run-tees **HV** in the 'C' ports toward the rear (Figure 4b - connect hoses to the run-tees later).

NOTE: Leave run-tees loose to allow for alignment when attaching hoses. Plastic caps placed on the open ends of the fittings will prevent excessive leakage prior to hose installation.

c. Disconnect the two steering hoses from the left side of the steering orbital (Figure 4c-i) and connect the hoses to the stems of the run-tees **HV** at the 'C' ports of the counterbalance valve (Figure 4c-ii).

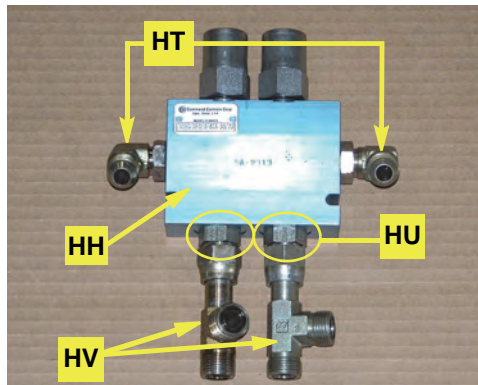

Figure 4a: Prepared counterbalance valve

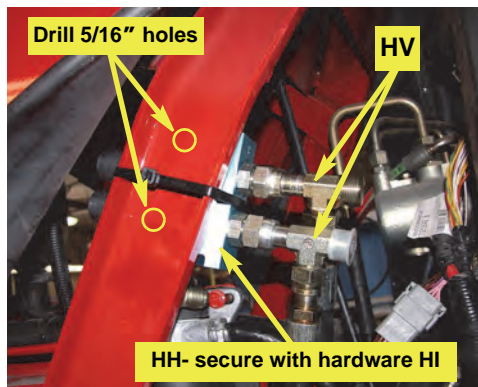

Figure 4b: Counterbalance valve location (you will connect hoses to the run-tees later)

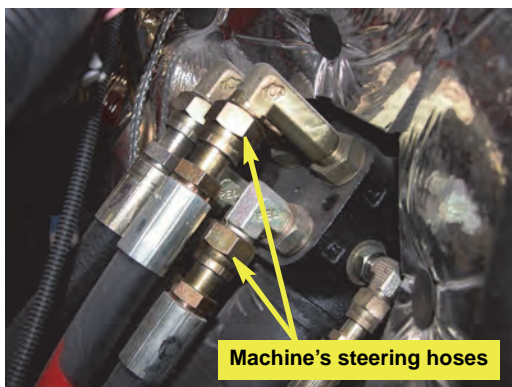

Figure 4c-i: Machine's steering hoses at orbital

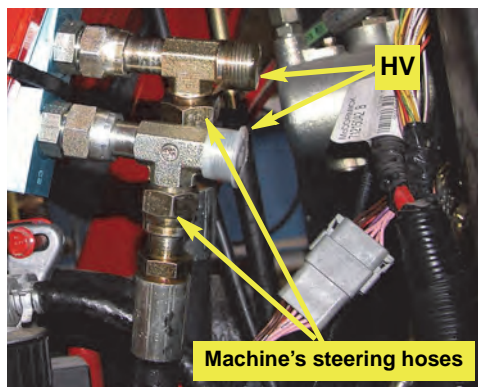

Figure 4c-ii: Machine's steering hoses at counterbalance valve run-tees

5. Install the steering hoses.

- a. Install the orbital/counterbalance valve steering hoses **HW** between the steering ports on the orbital and adapter fittings **HT** in the 'V' ports of the counterbalance valve (Figure 5a with insets).

NOTE:

*Do not cross hose connections when installing hoses at the counterbalance valve. The steering hoses connected to the **V1** and **V2** ports will apply pressure to the steering cylinders connected to the **C1** and **C2** ports respectively. For example, if the hose connected to the **L**(eft) port on the orbital (Figure 5a lower inset) connects with **V1**, then the machine's hose connected to the left steering cylinder must connect to the **C1** port.*

- b. Install hydraulic steering block/counterbalance steering hoses **HX** between the open 'T' ends of run-tees **HV** at the counterbalance valve and fittings **HC** in the A and B ports of the hydraulic steering block (Figure 5b with inset).

6. Install the pressure and tank fittings.

- a. Locate the pressure and tank connections at the orbital. The pressure port is at the bottom right, the tank port is at the top right (Figure 6a with inset).

NOTE:

Your machine's pressure and tank hoses have straight ends (onto elbow fittings - Figure 6a) or elbow ends (onto straight fittings - Figure 6a inset).

- b. Disconnect the pressure and tank hoses and install run-tees **HM** and reconnect the machine's hoses to the open 'T' end of each run-tee (Figure 6b - but see note following).

NOTE:

*If your machine's hoses have elbow ends, use adapters **HN** between the orbital and the run-tees **HM** and connect the machine's hoses to the stem of each run-tee (Figure 6b inset)*

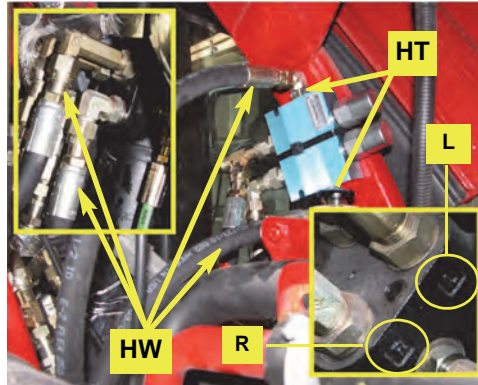

Figure 5a with insets: Steering hoses installed between orbital (insets) and counterbalance valve

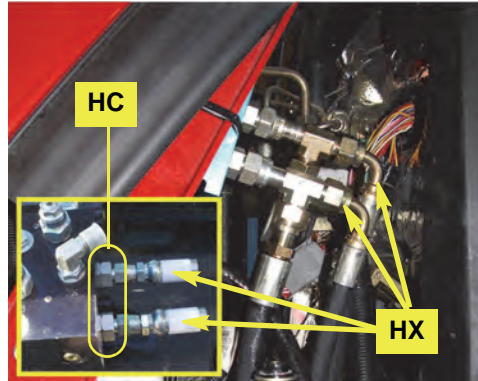

Figure 5b with inset: Steering hoses at run-tees at counterbalance valve and (inset) at hydraulic steering block

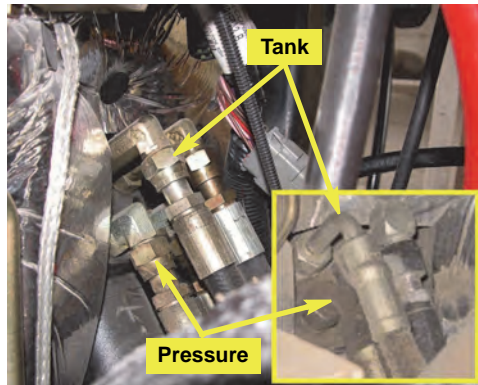

Figure 6a with inset: Pressure and tank hoses at orbital (inset - alternative elbow-end hoses)

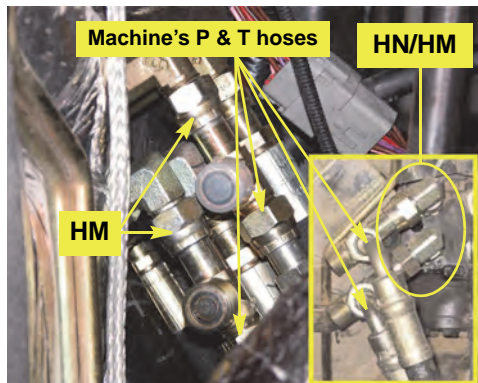

Figure 6b with inset: P and T run-tees installed

7. **Install the pressure and tank hoses.**

Install pressure and tank hoses **HY** between adapters **HB** in the **P** and **T** ports of the hydraulic steering block (Figure 7) and either the stem (Figure 7 inset) or the open ‘T’ end of the run-tees **HM**.

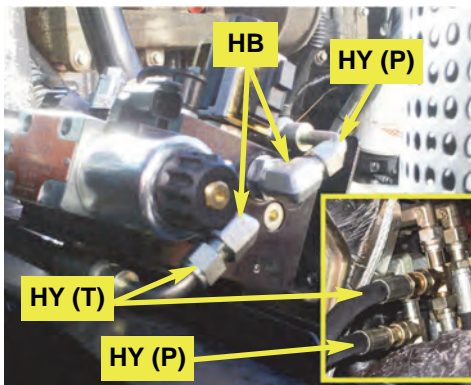

Figure 7: Pressure and tank hoses at steering valve and (inset) orbital

8. **Prepare and install the load sense shuttle valve.**

a. Prepare load sense valve **HO** by installing adapter fittings as follows (Figure 8a):

- **HP** in the valve’s source port
- **HQ** in the valve’s function port
- **HR** on **HQ**
- **HS** in the valve’s load sense port (to hydraulic steering block).

NOTE:

In the following steps, leave connections loose to allow for alignment when attaching the load sense hose.

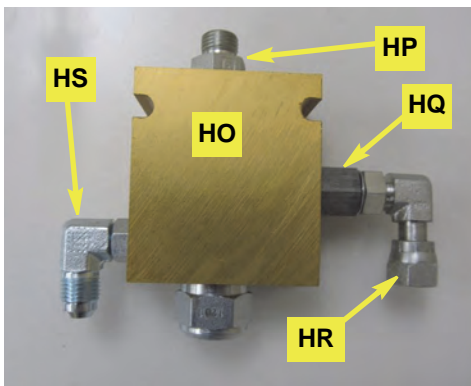

Figure 8a: Prepared load sense valve

b. Locate the machine’s load sense line on the left side of the orbital and disconnect it (Figure 8b).

Connect adapter **HR** (on **HQ**) in the load sense valve to the open orbital fitting (Figure 8b). Connect the load sense line you disconnected from the orbital to adapter **HP** in the load sense valve source port (Figure 8b inset).

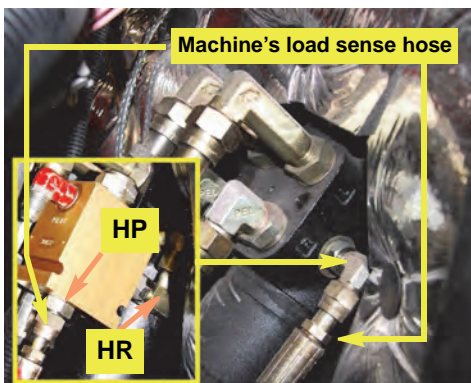

Figure 8b with inset: Load sense valve installed, machine’s load sense hose reconnected

c. Install load sense hose **HZ** between adapter **HS** in the load sense valve (Figure 8c) and adapter **HD** in the **LS** port of the hydraulic steering block (Figure 8c inset).

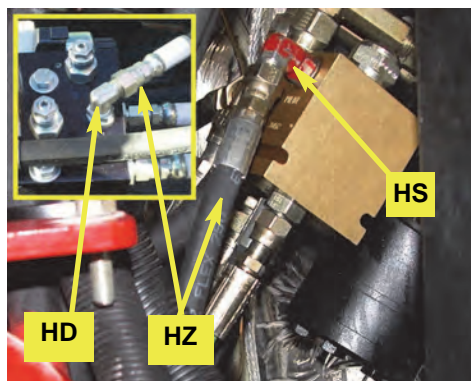

Figure 8c with inset: Load sense hose installed

9. Install the steering controller.

Using hardware **HL**, install steering controller **HK** on its bracket **HJ**. Mount the controller with its connector sockets upward and the pressure wash warning outward (Figure 9).

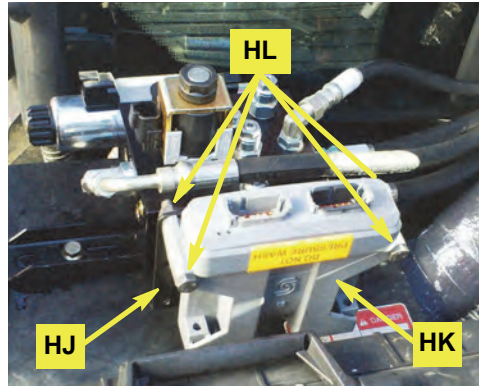

Figure 9: Steering controller installed

10. Verify operation.

⚠ WARNING: *During tests of the hydraulic system, the machine may move unexpectedly. Be prepared for machine movement to avoid injury.*

Keep others away and stay clear of mechanical steering linkages to prevent serious injury or death from pinch point hazards while manually operating the hydraulic steering circuit.

- a. Tighten all connections and clean up the installation area around the machine and make certain that it is safe to operate.
- b. Start the machine and check hydraulic connections for any leaks.
- c. Rotate the steering wheel from one extreme to the other and back.

Installation - Wheel Angle Sensor (WAS)

⚠ WARNING:

Switch off the machine's engine while installing or adjusting the WAS. Keep others away and stay clear of mechanical steering linkages to prevent serious injury or death from pinch point hazards while manually operating the hydraulic steering circuit.

1. Prepare the wheel angle sensor.

- Using the provided hardware **WE** (nuts) and **WD** (bolts - not visible), attach the WAS wire connector **WB** to the WAS housing **WA**. Install the bolts up through the bottom of the housing. For all except ZTX machines, set the WAS wire connector **WB** at 90° to any of WAS housing **WA**'s sides (Figure 1a). For ZTX machines set **WB** at slightly less than 90° (this will point **WB** slightly toward the front of the machine when installed - Figure 1a inset).
- For all except ZTX machines, cut seven holes off WAS arm **WC** at the opposite end from the WAS shaft mounting hole (Figure 1b). For ZTX machines cut six holes off.
- Using hardware **WF** (screw) and **WE** (nut), attach the WAS arm **WC** to the WAS assembly. Mount the arm in the opposite direction to the WAS wire connector **WB** (Figure 1c with inset).

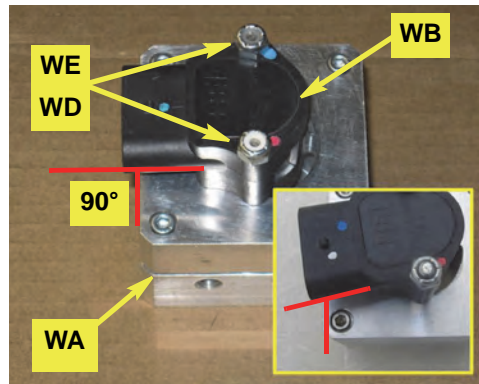

Figure 1a: Prepared WAS housing/connector

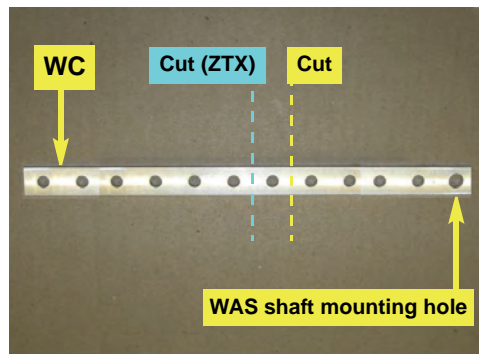

Figure 1b: WAS arm preparation

NOTE:

Before you cut the rod at step d, screw the provided nuts **WH** onto the threaded rod **WG** so that they are inside the cut you will make. After you have cut the rod, the nuts can help clean the threads.

- For all except ZTX machines, cut threaded rod **WG** to 5¼" long (Figure 1d-i) then screw swivel rod ends **WI** onto the cut rod to achieve a center-to-center stud measurement of 6½" (Figure 1d-ii). For ZTX machines, cut **WG** to 3¾" long to achieve a center-to-center stud measurement of 5". Leave **WH** loose until you complete linkage adjustment at step 2f.

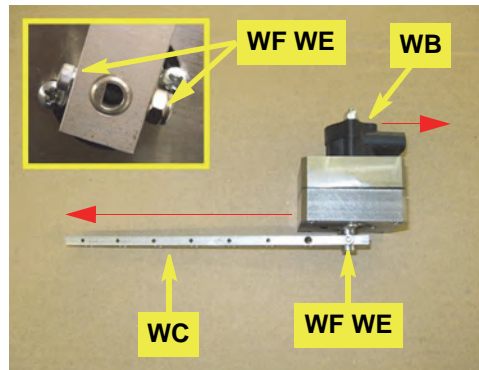

Figure 1c with inset: WAS arm installed

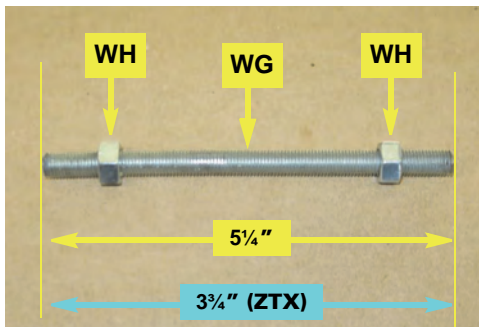

Figure 1d-i: Threaded link rod preparation

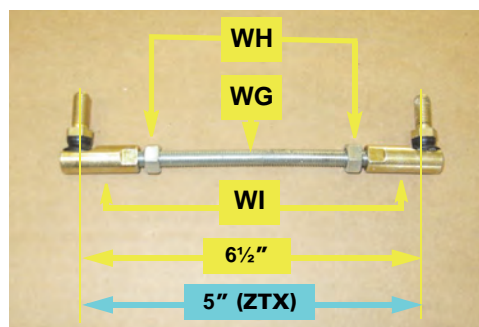

Figure 1d-ii: Assembled threaded rod link

2. Mount the wheel angle sensor.

NOTE:

The figures in this section may show prototype brackets and fittings. Install your brackets and fittings as described. The Figures show the MX, MTX, WXTX installation.

- a. For ZTX machines only, cut the thick corner off the single-hole end of WAS assembly bracket **WK** (Figure 2a right inset). Mount **WK** on the back of the right front axle. Use the bolt nearest (and below) the outer end of the steering cylinder (Figure 2a and left inset). Mount the bracket with its WAS assembly flange pointing to the rear (Figure 2a).
- b. Using bolts **WJ**, mount the WAS assembly (from steps 1a -1c) on bracket **WK**. Mount the assembly with wire connector **WB** at the bottom and facing inward (toward the machine—and, for ZTX machines, slightly toward the front) and **WC** facing outward (Figure 2b).

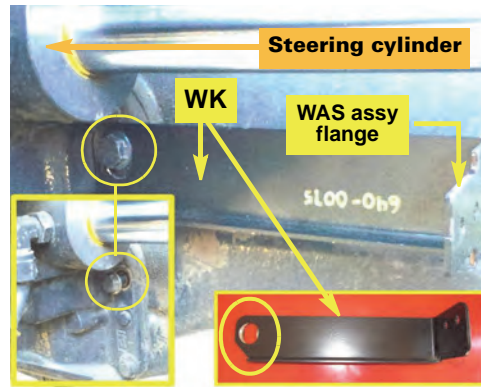

Figure 2a with insets: WAS mounting bracket installed (right inset - WK modification for ZTX)

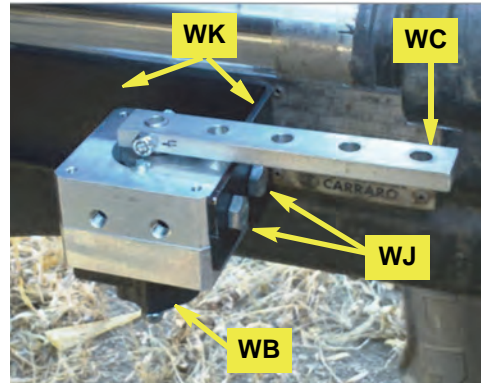

Figure 2b: WAS assembly installed

- c. Using hardware **WN** mount clamp **WM** and link rod bracket **WL** on the right tie rod. Mount **WL** toward the rear, vertically and with its rod hole downward (Figure 2c, top). Set the centerline of the clamp/bracket assembly $9\frac{1}{2}$ " from the center of the tie rod end (Figure 2c, bottom).

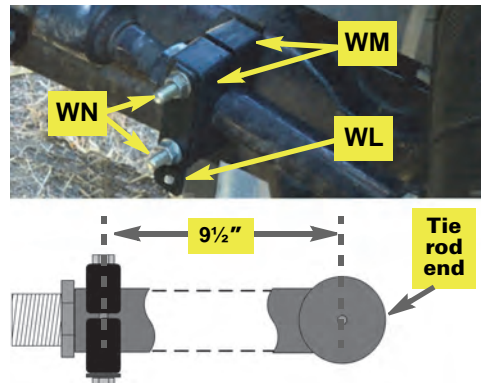

Figure 2c: WAS link rod bracket installed

- d. Using nuts **WH**, install the link rod assembly from step 1 between the last hole in WAS arm **WC** and bracket **WL**. Set the swivel stud upward into **WC**, forward into **WL** (Figure 2d). Leave **WH** loose.

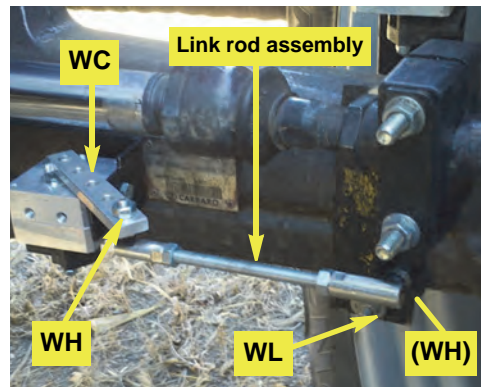

Figure 2d: WAS link rod installed

2. **Mount the wheel angle sensor (continued).**

- e. With all **WH** nuts loose, slowly turn the wheels full left lock then full right lock. Check that the linkage moves freely without binding and adjust the linkage as necessary (Figures 2e-i and 2e-ii).
- f. When the linkage does move freely and without binding, tighten **WH** on the rod and the swivels (Figure 2e-ii).



Figure 2e-i: Full left lock

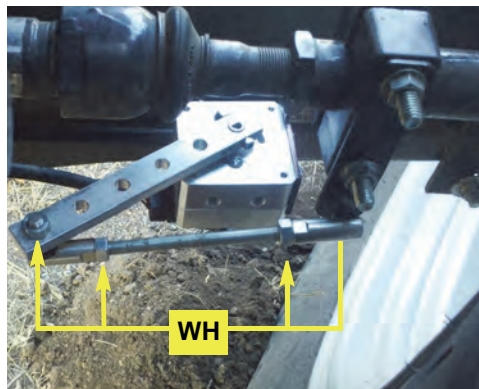

Figure 2e-ii: Full right lock

Installation - Steering Wheel Switch (SWS)

1. Access the steering column.

Retract the floor mat at the bottom of the steering console and remove the lower section of the console to expose the steering shaft shield (Figure 1).



Figure 1: Steering column lower/side console removed, steering shaft shield exposed

2. Prepare the switch/sensor bracket.

Drill a 3/8" hole in the switch/sensor bracket **SC** at the opposite end from the pre-drilled 5/16" hole. Put a 90° bend in the end of the bracket with the 3/8" hole (Figure 1c).

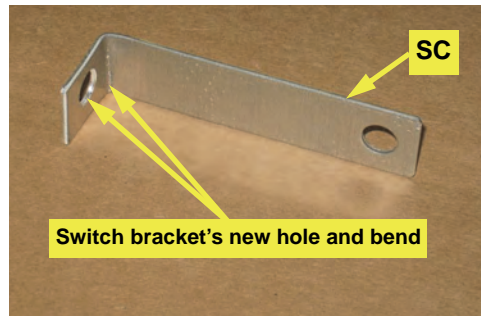

Figure 2: Switch bracket with new hole and bend

3. Install the switch bracket, magnets and switch.

a. Remove the center steering shaft shield flange bolt (nearest the driver's seat). Mount bracket **SC** on the bolt and align it squarely with the shaft shield (Figure 3a - **SC** not shown).

b. Using **SC** as a template, mark the shield then drill a 1/2" hole in the shield (Figure 3a inset - the hole center will be approximately 2 3/4" from the base of the shield).

c. Cut one magnet **SA** in half then trim each half into shape to pass through the 1/2" hole (keep the magnet as big as possible, round for example).

d. Using the two-part epoxy **SB**, attach one half of the magnet to the inner steering shaft. Turn the shaft 180° and attach the other half of the magnet to the steering shaft (Figure 3b inset).

e. Reinstall bracket **SC** and align the switch hole with the magnets hole (Figure 3b inset).

Install switch **SD** in **SC** and adjust it so that the sensor face is 1/8" to 1/4" from the magnets (Figure 3b).

You will connect **SD**'s cable later.

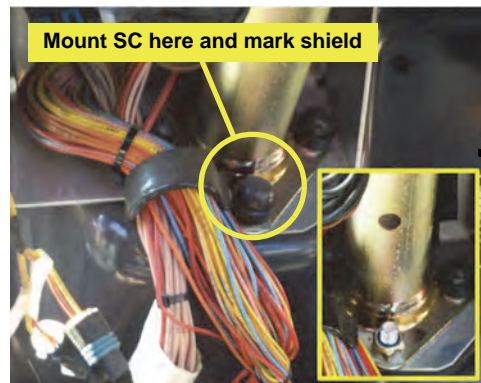

Figure 3a with inset: Mark and drill the steering shield

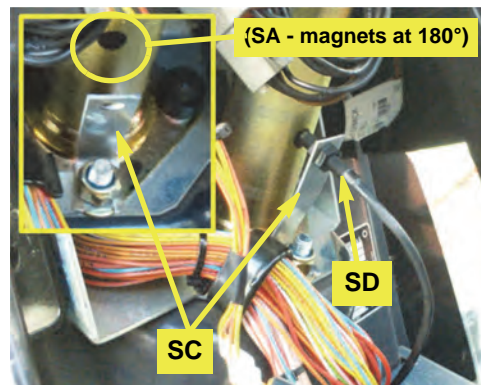

Figure 3b with inset: Magnets and switch installed

Installation - Electronic Control Unit (ECU)

See Appendix A for a schematic of the cable connections.



Before drilling (or using self-drilling screws) in the cab, make sure there is nothing that can be damaged by the drilling or by any self-drilling screws used to secure the ECU mounting bracket. Secure anything that could be damaged away from where the screws come through. See Figure 1 for an example of a pre-drilling check; it shows an under-floor cabling compartment.

1. Install the ECU.



Although measurements and floor mat references provide an accurate guide, ensure that when installed, the bracket will be perpendicular to the front of the machine (that is, parallel to the machine's fore/aft centerline). Also, use a small level to set the bracket as level as possible - see steps following.

- a. Identify the ECU mounting location on the cab floor inside the right door.

Facing the one-inch tabs of bracket **EJ** toward the right door, set the bracket so that (Figure 1a):

- The outer edge of the front one-inch tab is at the outer edge of the fourth mat rib (counting from the front)
- The front edge of the bracket base is along the front edge of the fourth mat rib

(This places the rear edge of the bracket base along the back edge of the eighth mat rib.)

Using hardware **EK**, fasten the bracket to the cab floor (Figure 1a inset). Use a small level (not shown) to check the level of the bracket. Adjust accordingly.



Do not overtighten the self-drilling screws. Overtightening could cause the fastener to fail.

- b. Using hardware **EM** attach the ECU **EI** to the inner face of bracket **EJ**. Have the connector sockets at the front and the power and communications indicators at the (rear) top (Figure 1b).



Figure 1: Example pre-drilling check

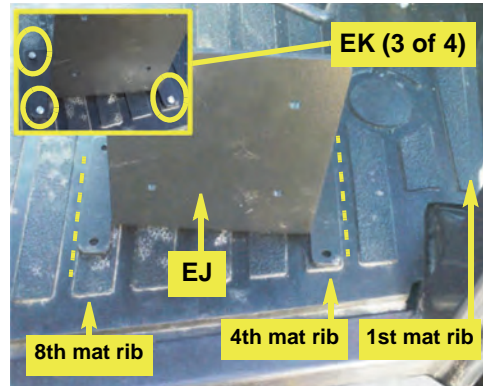

Figure 1a with inset: ECU mounting bracket location/installed

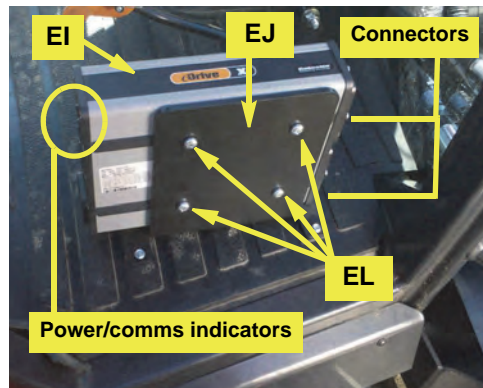

Figure 1b: ECU installed

2. **Assemble and install the cables.**

On a clean surface, lay out all the cables and become familiar with the connections and where they are to be connected. See Appendix A.

- a. Connect cable **EA** to the ECU **EI** using an Allen wrench to secure the cable to the ECU (Figure 2a). The **EA** connector will fit only the ECU socket that is in line with the power and communications indicators at the opposite end of the ECU. Connect **EA** to the top socket on **EI** in this installation.

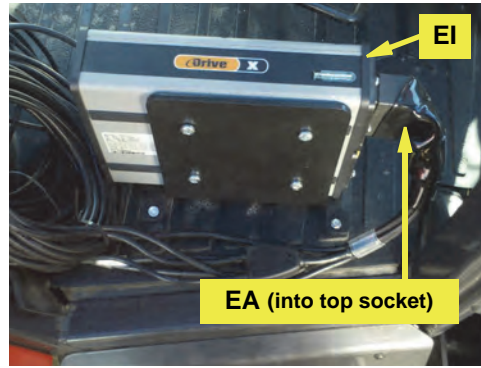

Figure 2a: Installed ECU main cable

- b. Connect steering controller cable **EC**'s two 12-pin connectors (black and gray) to their respective sockets on the steering controller **HK** (Figure 2b).

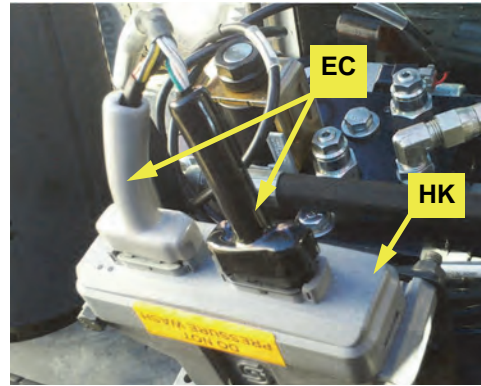

Figure 2b: Steering controller's two 12-pin connections

- c. Connect valve cable **ED** to **EC**'s connector labeled 'VALVE'. Connect **ED**'s three 2-pin connectors (labeled 'LEFT', 'RIGHT' and 'ENABLE') to the enable valve and two solenoid valves on the hydraulic steering block (Figure 2c).

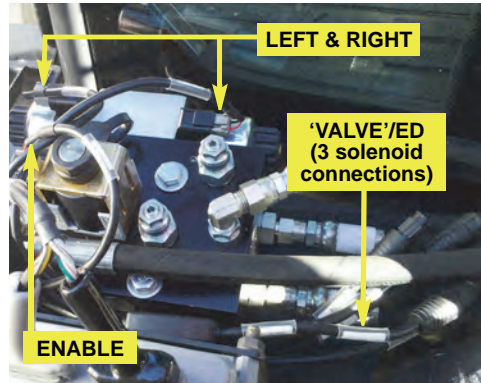

Figure 2c: Valve cable from steering controller to cable for left, right and enable solenoids

- d. Install extension cable **EB** between steering controller cable **EC**'s connector labeled 'ECU' (Figure 2d) and, in the cab, **EA**'s connector labeled 'STEERING CONTROLLER'.

- e. Install SWS cable **EF** between steering controller cable **EC**'s connector labeled 'SWS' (Figure 2d) and, in the cab, steering wheel switch connector **SD**.

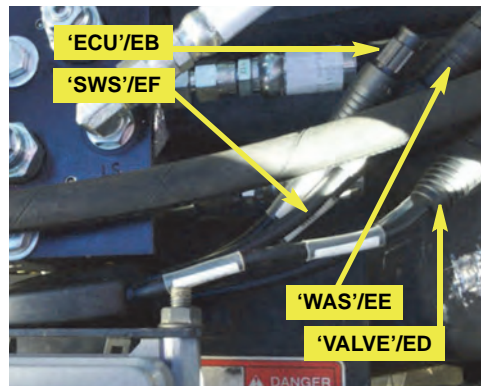

Figure 2d: Steering controller cable connections to function cables

2. Assemble and install the cables (*continued*).

- f. Connect WAS cable **EE** to **EC**'s connector labeled 'WAS' (Figure 2d). Route **EE** to the WAS assembly on the right front axle. Connect **EE** to **WB**'s wire connector (Figure 2e).

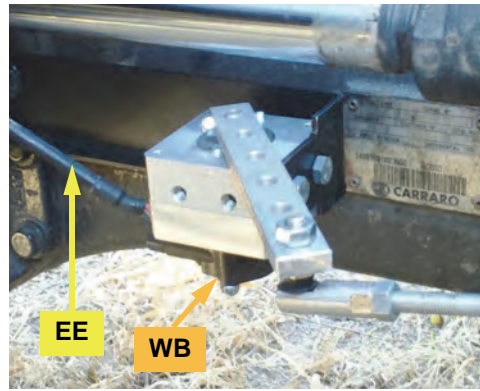

Figure 2e: WAS cable at WAS connector

- g. Route extension cable **EB**, SWS cable **EF** and the power cable to the battery in/out of the cab through the access hole in the floor at the bottom of the right console, just inside the bottom rear corner of the door frame (Figure 2f with inset). Outside the cab use cable ties **Ha** to secure cables with other cables or plumbing when routing the cables to the steering controller connections at the hydraulic steering block or the battery.
- h. Attach power switch **EG** to cable **EA**'s connector labeled 'SWITCH'. Some machines are equipped with pop out tabs that you can remove and replace with switch **EG**. If no tab is available, you can use bracket **EGa** mounting it in the cab at the operator's preferred location.

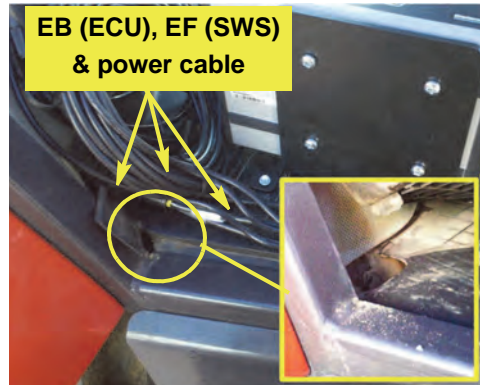

Figure 2f with inset: Cabling into (or out from) ca

NOTE: Set the switch to OFF before connecting **EA** to the battery at step j.

- i. Install CAN-PWR cable **EH** between **EA**'s open connection labeled 'TERMINAL/RECEIVER' and the guidance terminal. Connect your battery terminal cable to **EH**'s remaining connector. Route cables in the cab so that they are clear of any machine operation controls.

NOTE: Ensure you have connected main cable **EA** to the ECU (step 2a, page 21) and reconnected **EA**'s power cable (after routing in/out of the cab) before you connect to the machine's battery at the next step.

- j. Route the power cable part of cable **EA** to the machine's 12V battery and connect it.

© Hemisphere GPS (2013). All rights reserved.

Appendix A - ECU Cables and Connections

ECU CABLES AND CONNECTIONS

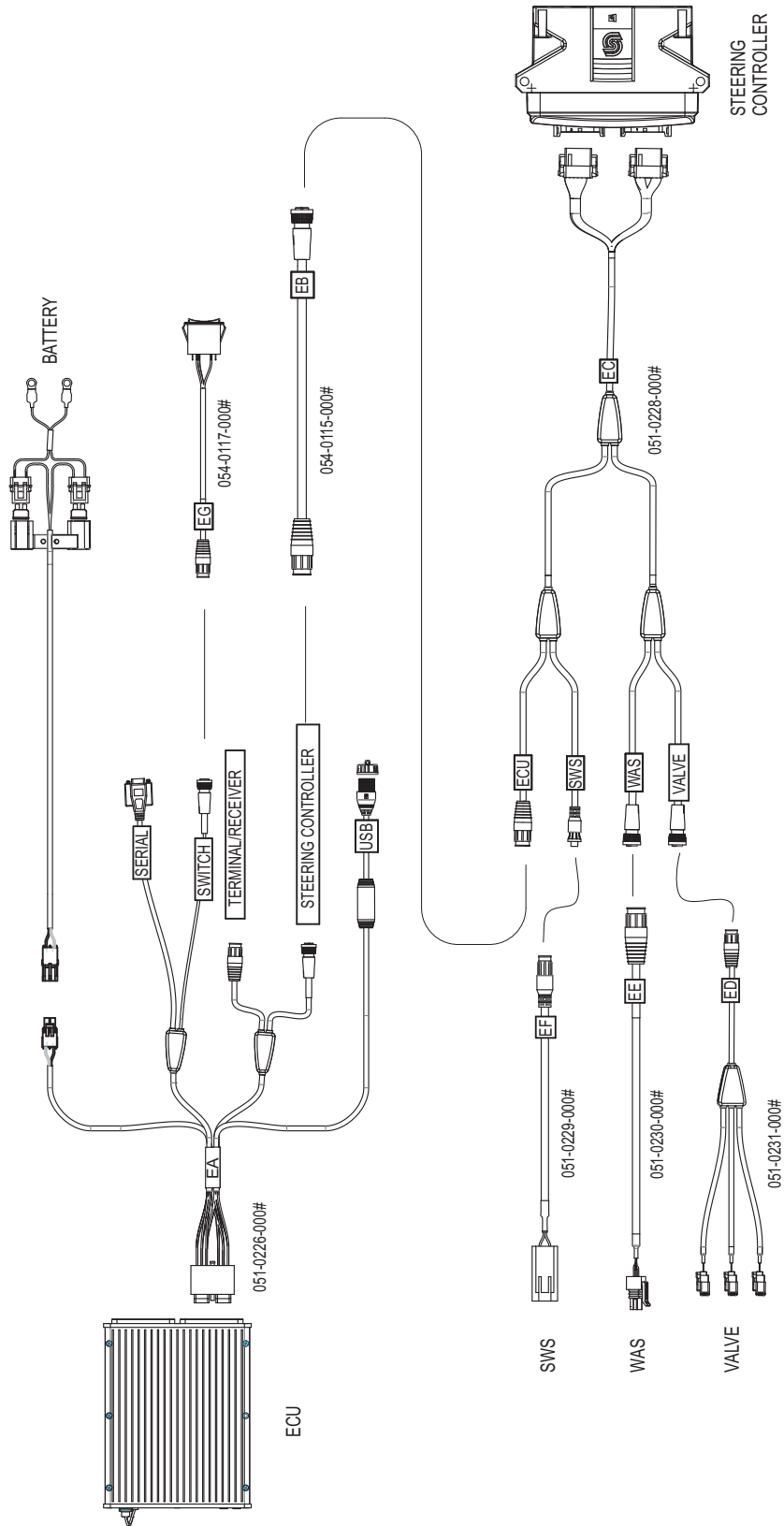

Appendix B - Hydraulic Circuits

