

# Installation Guide

Installation Kit: 911-6114-10



## Case IH

7110	7240
7120	7250
7130	8910
7140	8920
7150	8930
7210	8940
7220	8950
7230	

# Introduction

---

The procedures outlined in this guide provide the basic installation procedure for the ESi<sup>2</sup> on the machines specified on the front cover of this guide. If you do not see your machine listed, contact customer support for further instruction. The kit components and corresponding install instructions are designated for each applicable machine make and model and may not be used on undesignated machine models.

## **Review Installation Kit Contents**

Kit contents are outlined in the ESi<sup>2</sup> installation section on pages 6 and 7. Read all applicable installation instructions for your machine's model and ensure that all required kit components are present before beginning the installation.

**NOTE:** Due to manufacturing processes outside of Outback Guidance's control, the installer may have to adapt this kit to your distinct situation.

## **Read and Follow All Safety Messages**

- Refer to the safety manual for the machine that the ESi<sup>2</sup> is being installed on for operating age and precautions.
- Prior to installing and operating the ESi<sup>2</sup>, read and understand all safety precautions as outlined in this guide
- Store this guide and all related safety information with related machine manuals for future reference.

## **Safety Information and Warnings\***

- ESi<sup>2</sup> is NOT designed to replace the machine's operator and is designed as a driving aid for use in precision agriculture applications.
- ESi<sup>2</sup> is NOT intended for use on roadways and should remain disengaged at all times when traveling on roadways.
- ESi<sup>2</sup> does NOT control the speed of the machine and a human operator is required to manually maintain a safe operating speed.
- ESi<sup>2</sup> does NOT avoid obstacles. To prevent human, machine and property injury a human operator is required to operate the machine at all times.
- Do NOT allow anyone to operate without instructions.
- At all times the driver is fully responsible for the safe operation of the vehicle.

\* The safety warnings contained in this installation guide are not meant to be an exhaustive list of potential hazards.

# Introduction

---

- To ensure peak performance, ESi<sup>2</sup> should only be installed after a thorough machine inspection has been conducted. The contents of this kit and ESi<sup>2</sup> are not intended to replace preventative and or needed maintenance. To avoid bodily and machine injury, follow the machine preparation checklist below:
  - ⇒ Inspect steering linkage: Machine should drive in a straight line without manual correction
  - ⇒ Turn off machine and power-off all electronic gauges, monitors and external devices when installing or performing maintenance on the ESi<sup>2</sup>
  - ⇒ Park machine on a clean and level surface
  - ⇒ Lower all implements and headers to the ground
  - ⇒ Apply the parking break and chock wheels
  - ⇒ Inspect any drilling and/or cutting sites to ensure no electrical wiring damage will be incurred

# Machine Preparation

---

Remove the steering wheel center cap and the nut holding the telescoping actuator knob on the shaft.

**SAVE** the nut as it will be used later in this installation.

Remove the telescoping actuator knob to gain access to the nut that holds the steering wheel onto the shaft.

Remove and **SAVE** this nut as it will be used later in this installation.

Following the manufacturer's recommended procedure remove the steering wheel.



**NOTE:** Consult your equipment dealer if you are unsure of the correct procedure for removing the steering wheel.

Remove the black plastic cylinder and washer that are around the steering shaft.

**SAVE** the black plastic cylinder and washer as they will be used later in this installation





# Machine Preparation

---

Pull down the rubber that covers the bottom portion of the steering column



Steering column is ready for ESi2 installation



# ESi<sup>2</sup> Installation

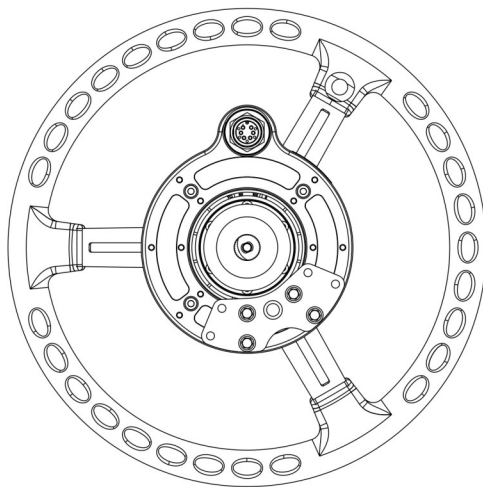
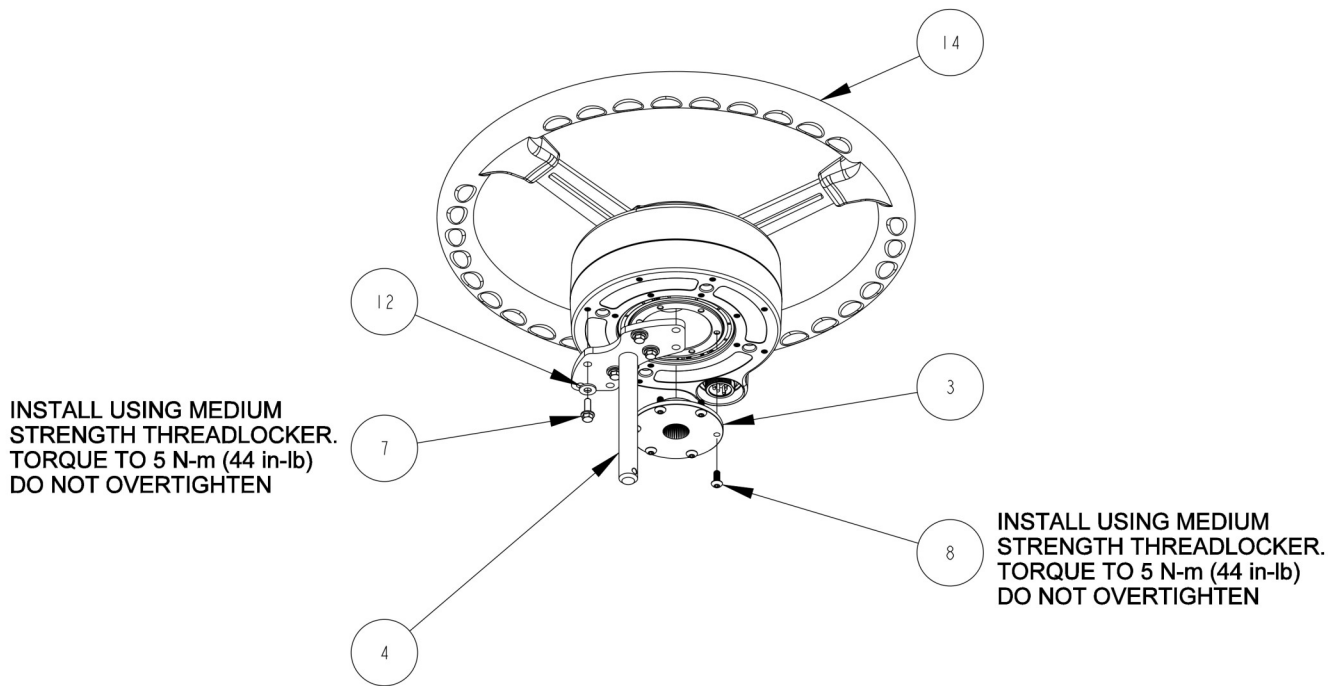

T-BAR INSTALLATION ORIENTATION

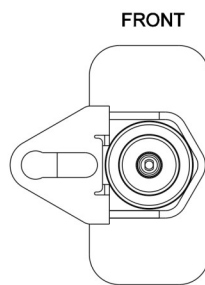

FRONT  
BRACKET INSTALLATION ORIENTATION

### ASSEMBLY INSTRUCTIONS:

1. PRE-ASSEMBLE SPLINE ADAPTER AND T-BAR TO WHEEL MOTOR AS SHOWN.
2. CLAMP THE BRACKET AND V-BOLT ONTO THE STEERING COLUMN AS SHOWN.
3. RE-INSTALL PLASTIC WASHER AND PLASTIC COVER.
4. INSERT BUSHING INTO SLOT IN BRACKET.
5. PLACE WHEEL ASSEMBLY ON STEERING SHAFT AND RE-INSTALL STEERING SHAFT NUT.
6. INSTALL TELESCOPING KNOB COMPONENTS AND CENTER CAP.
7. INSTALL RETAINING PIN IN T-BAR.

# ESi<sup>2</sup> Installation

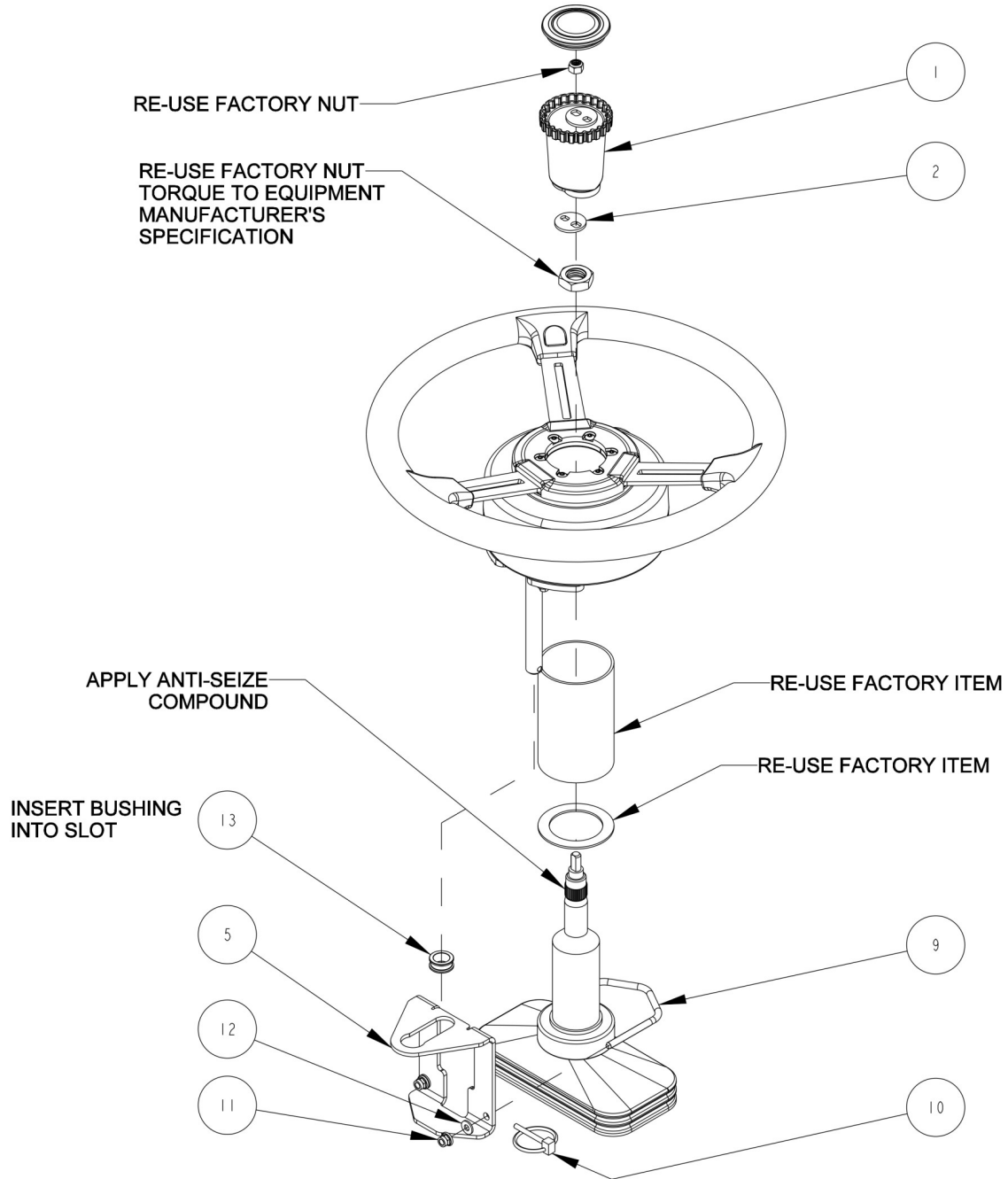

ITEM	QTY	PART NUMBER	DESCRIPTION	NOTES
1	1	600-1486-01	TELESCOPING ACTUATOR KNOB	
2	2	601-1290-01	TELESCOPING ACTUATOR PLATE	
3	1	604-0074-10	SPLINE ADAPTER- ESI2, 36T x .875 MAJOR x .180/.870 OFFSET	
4	1	640-0183-01	T-BAR	
5	1	640-0189-10	ANTI-ROTATION BRACKET, ESI2, IH 88 TILT WHEEL	
6	1	675-0126-000	LOCTITE 242 MEDIUM STRENGTH THREADLOCKER	NOT SHOWN
7	4	675-1348-10	SCREW, M5-0.8 X 16mm, HEX FLANGE	
8	6	675-1351-10	SCREW, M5-0.8 X 12mm, BUTTON HEAD	
9	1	675-2084-01	V-BOLT, 3.30 X M6	
10	1	676-0037-000	RETAINING PIN	
11	2	676-1089-000	NUT, M6X1.0 ,NYLOCK, FLANGED, ZP	
12	6	678-1148-10	WASHER, #12 SAE .250 ID X .562 OD	
13	1	699-0027-01	BUSHING, SPHERICAL	
14	1	910-4024-10	ESI2 ELECTRIC STEERING WHEEL	

# ESi<sup>2</sup> Installation Completed

---

ESi<sup>2</sup> wheel successfully installed





## Install Completion Checklist

---

- Ensure steering wheel turns freely and anti-rotation brackets do not contact the spline adapter.
- Check, and if needed, tighten anti-rotation brackets to eliminate excess movement. Loose anti-rotation brackets can cause poor steering performance.
- For steering ECU installation instructions please refer to the ECU installation guide that came with your installation kit.