

Installation Guide

Installation Kit: 911-6117-10



Gleaner

R55

R65

R75

A65

A75

A85

Massey Ferguson

9690

9790

Challenger

660

670

Introduction

The procedures outlined in this guide provide the basic installation procedure for the ESi² on the machines specified on the front cover of this guide. If you do not see your machine listed, contact customer support for further instruction. The kit components and corresponding install instructions are designated for each applicable machine make and model and may not be used on undesignated machine models.

Review Installation Kit Contents

Kit contents are outlined in the ESi² installation section on pages 6 and 7. Read all applicable installation instructions for your machine's model and ensure that all required kit components are present before beginning the installation.

NOTE: Due to manufacturing processes outside of Outback Guidance's control, the installer may have to adapt this kit to your distinct situation.

Read and Follow All Safety Messages

- Refer to the safety manual for the machine that the ESi² is being installed on for operating age and precautions.
- Prior to installing and operating the ESi², read and understand all safety precautions as outlined in this guide
- Store this guide and all related safety information with related machine manuals for future reference.

Safety Information and Warnings*

- ESi² is NOT designed to replace the machine's operator and is designed as a driving aid for use in precision agriculture applications.
- ESi² is NOT intended for use on roadways and should remain disengaged at all times when traveling on roadways.
- ESi² does NOT control the speed of the machine and a human operator is required to manually maintain a safe operating speed.
- ESi² does NOT avoid obstacles. To prevent human, machine and property injury a human operator is required to operate the machine at all times.
- Do NOT allow anyone to operate without instructions.
- At all times the driver is fully responsible for the safe operation of the vehicle.

* The safety warnings contained in this installation guide are not meant to be an exhaustive list of potential hazards.

Introduction

- To ensure peak performance, ESi² should only be installed after a thorough machine inspection has been conducted. The contents of this kit and ESi² are not intended to replace preventative and or needed maintenance. To avoid bodily and machine injury, follow the machine preparation checklist below:
 - ⇒ Inspect steering linkage: Machine should drive in a straight line without manual correction
 - ⇒ Turn off machine and power-off all electronic gauges, monitors and external devices when installing or performing maintenance on the ESi²
 - ⇒ Park machine on a clean and level surface
 - ⇒ Lower all implements and headers to the ground
 - ⇒ Apply the parking break and chock wheels
 - ⇒ Inspect any drilling and/or cutting sites to ensure no electrical wiring damage will be incurred

Machine Preparation

Remove the steering wheel center cap and the nut holding the steering wheel onto the shaft.

SAVE the nut as it will be used later in this installation.

Following the manufacturer's recommended procedure remove the steering wheel.

NOTE: Consult your equipment dealer if you are unsure of the correct procedure for removing the steering wheel.



Steering column is ready for ESi² installation.



ESi² Installation

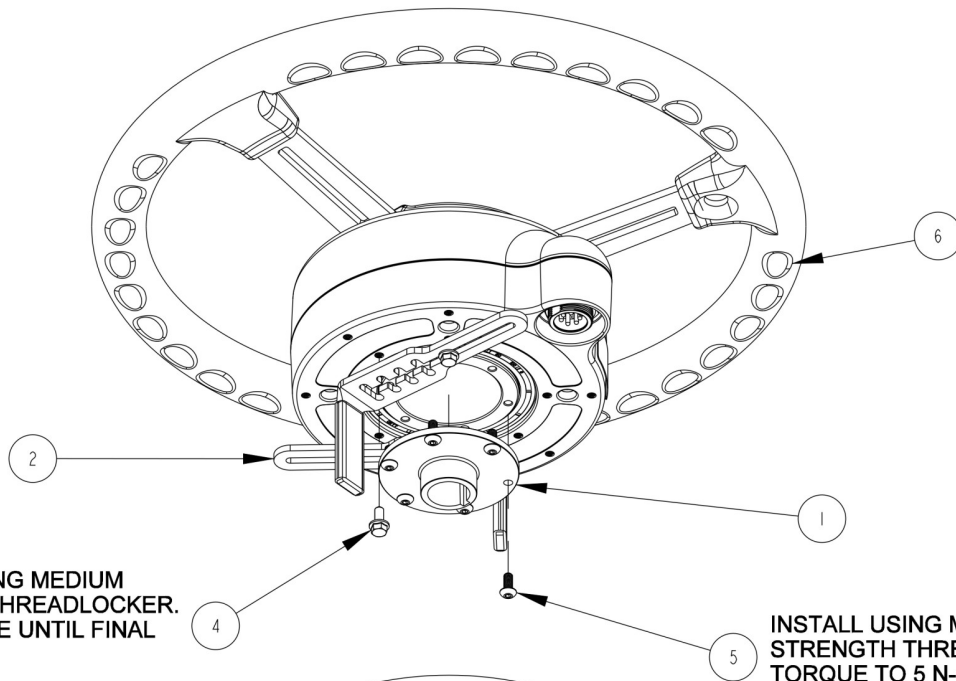

BRACKET ORIENTATION

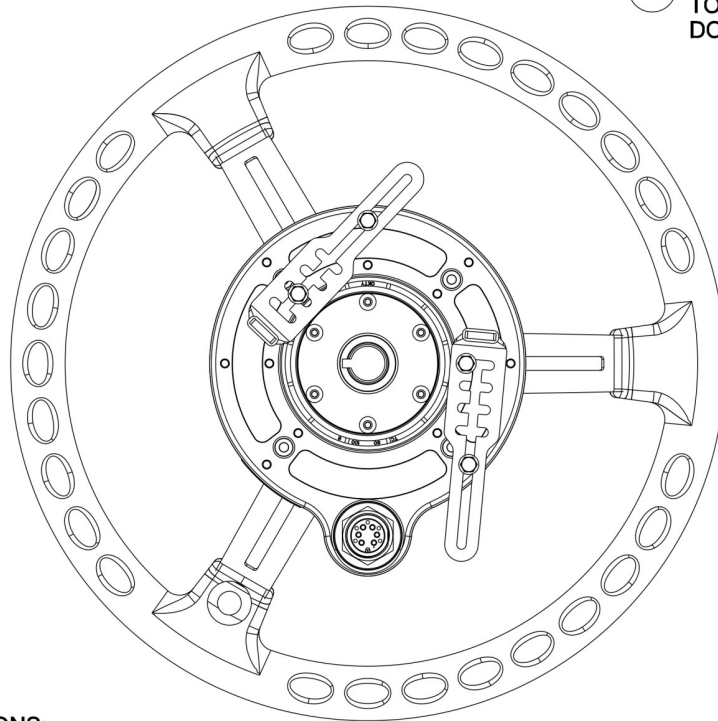

ASSEMBLY INSTRUCTIONS:

1. PRE-ASSEMBLE SPLINE ADAPTER AND BRACKETS TO WHEEL MOTOR.
2. PLACE ASSEMBLY ON STEERING SHAFT AND RE-INSTALL STEERING SHAFT NUT.
3. ADJUST BRACKETS TO FIT SNUG AGAINST THE STEERING COLUMN.
4. TIGHTEN SCREWS ATTACHING BRACKETS TO BOTTOM OF MOTOR. TORQUE TO 5 N-m (44 in-lb). DO NOT OVERTIGHTEN. ENSURE THAT THE ANTI-ROTATION BRACKETS DO NOT CONTACT THE SPLINE ADAPTER. ENSURE THAT THE MOTOR DOES NOT MOVE IN RELATION TO THE STEERING COLUMN.
5. ROTATE THE WHEEL A FULL TURN TO ENSURE THERE IS NO INTERFERENCE BETWEEN THE BRACKETS AND SPLINE ADAPTER, OR ANY MOVING PARTS AND MACHINE CONTROLS.

ESi² Installation

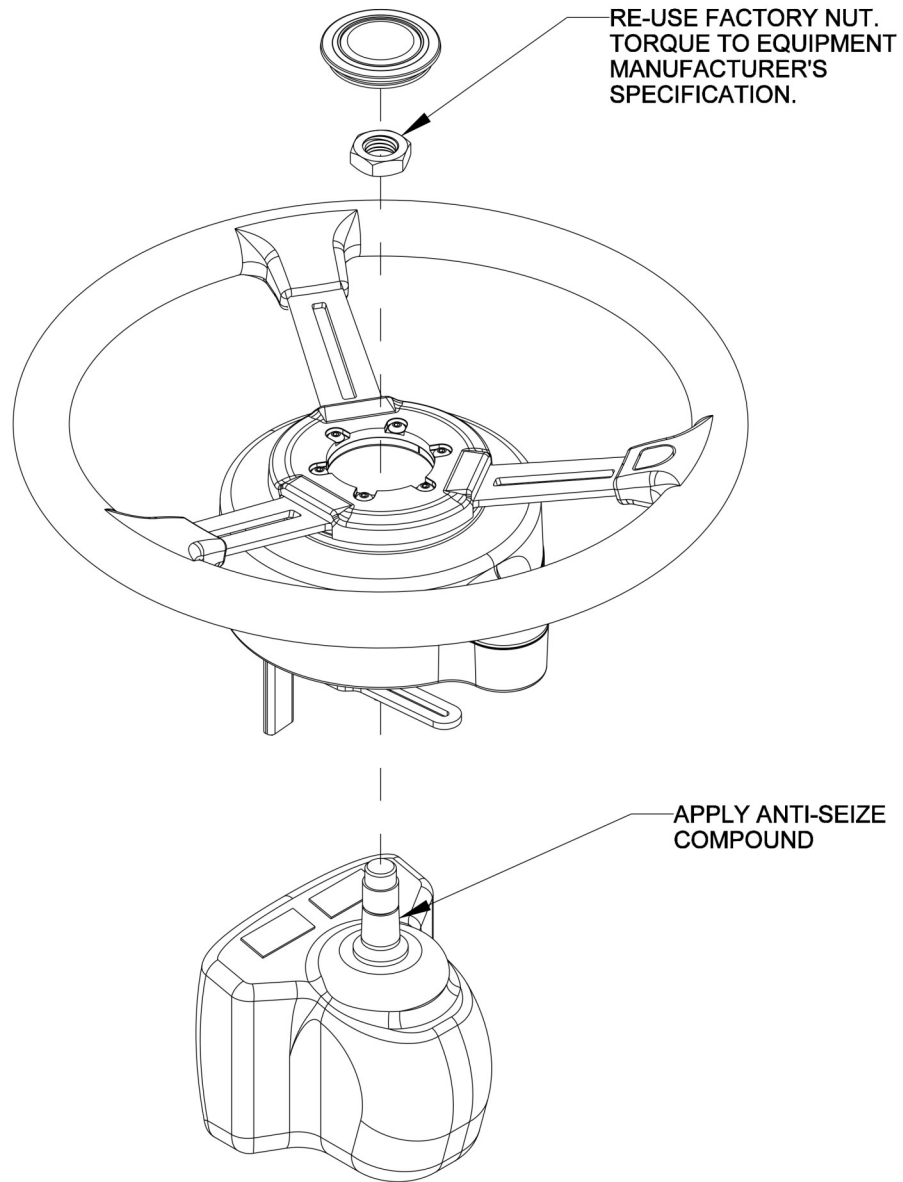

ITEM	QTY	PART NUMBER	DESCRIPTION	NOTES
1	1	604-0079-10	SPLINE ADAPTER- ESI2, KEYED x .910 MINOR DIA TAPER x .740 OFFSET	
2	2	640-0184-01	ANTI-ROTATION BRACKET	
3	1	675-0126-000	LOCTITE 242 MEDIUM STRENGTH THREADLOCKER	NOT SHOWN
4	4	675-1345-10	SCREW, M5-0.8 X 12MM, HEX FLANGE	
5	6	675-1351-10	SCREW, M5-0.8 X 12MM, BUTTON HEAD	
6	1	910-4024-10	ESI2 ELECTRIC STEERING WHEEL	

ESi² Installation Completed

ESi² wheel successfully installed



Install Completion Checklist

- Ensure steering wheel turns freely and anti-rotation brackets do not contact the spline adapter.
- Check, and if needed, tighten anti-rotation brackets to eliminate excess movement. Loose anti-rotation brackets can cause poor steering performance.
- For steering ECU installation instructions please refer to the ECU installation guide that came with your installation kit.